

This information is provided by:



Gross Automation
1725 S. Johnson Rd.
New Berlin, WI 53146-1240
(877) 268-3700 Fax: (877) 268-9700



CONNECTION



AUTOMATION



CONTROLS



PROTECTION



Accessories markers, additional products

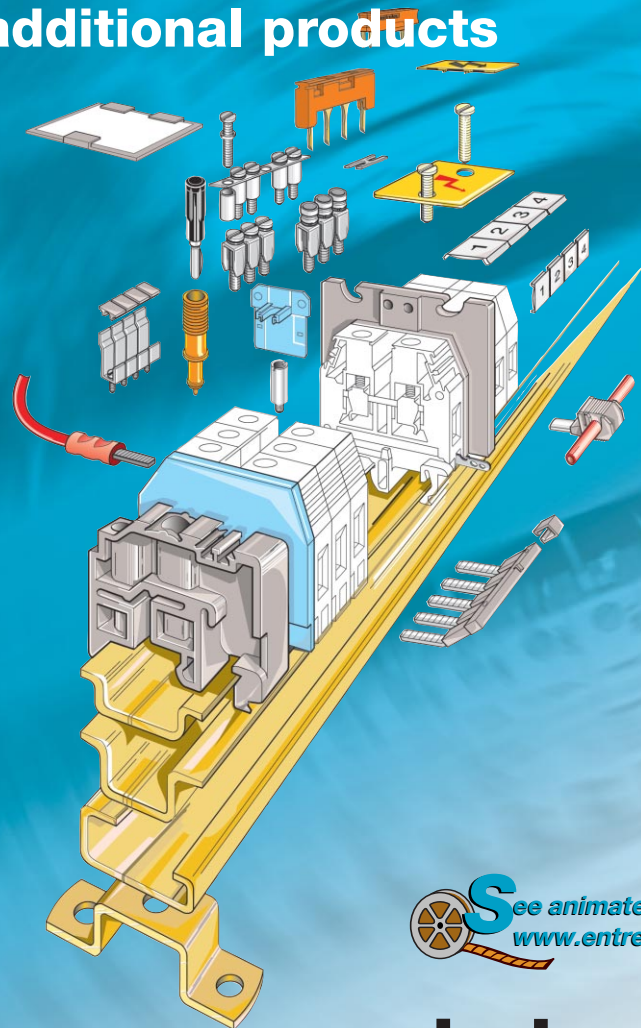

 See animated demo on www.entrelec.com.

entrelec[®]

13 Accessories

PRODUCT HIGHLIGHTS

SCREWLESS END STOPS



Screwless end stops snap onto the rail and stay in position by a friction fit. As well, these end stops require no tool for insertion and no screws to tighten. The end stop is repositioned by removing it from the rail with a screwdriver and reinserting it again on the rail. Models available for symmetrical DIN 2 and DIN 3 rails.

Page 1901

SCREWLESS JUMPER BARS

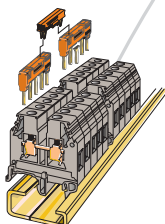

This accessory permits the interconnection of consecutive or nonconsecutive terminal blocks. Contact is made by simple insertion of the jumper bar into the central hole of the current bar on either compression clamp or ADO terminal blocks. A screwless jumper bar is also available for spring connection blocks.

Pages 1917-1918

FERRULES

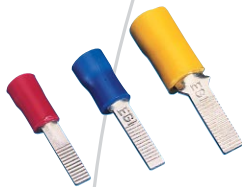

Choose from a complete range of insulated or noninsulated ferrules to simplify wire insertion. Single wire insulated ferrules accept wire sizes from 22 AWG to 0 AWG. Twin insulated ferrules accept two wires from 2 x 22 AWG to 2 x 6 AWG. Ferrules are ideal for applications where repetitive connect and disconnect of stranded wire is required. Accomplish wire crimping easily with a standard plier type crimping tool.

Pages 1922-1924

CUSTOM MARKERS

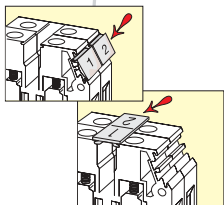

High quality custom marking on cards of 100 markers or on top marking strips for terminal blocks or printed circuit board terminal blocks. Our computer controlled plotter prints custom alphanumeric comprised of numbers, letters, or symbols on one or two lines per marker. The plotter can mix horizontal and vertical marking on a marker card. Designate your own requirements using our marker order forms.

Pages 1940-1945

DIN RAILS

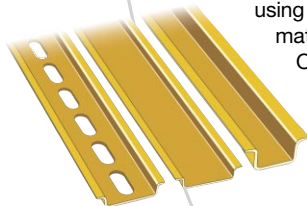

A complete line of symmetrical DIN 2 and DIN 3 rails and asymmetrical DIN 1 rails in one and two meter standard lengths. Rails are manufactured using zinc bichromate plated steel with an additional selection of other materials including galvanized steel, aluminum, copper, and plastic. Order solid rails or rails with prepunched mounting cutouts. Rail cutter, with four built-in dies or single interchangeable die, is available for custom cutting of rail lengths.

Pages 1895-1899

TOOLS



Hand and semi-automatic tools to facilitate connection and stripping of wires for insertion into terminal blocks. Hand tools include precision screwdrivers, wire stripping devices, and ferrule crimping tools. For high speed and high reliability connections, use the ADO insulation displacement, semi-automatic tool for one-step wire connections. All tools are easy to operate.

Pages 1900, 1915, 1924

OF SPECIAL INTEREST

ACCESSORIES

Descriptive diagrams to facilitate use of accessories

Accessories illustration	1894
Rail cutter	1898
Cover assembly	1911
Use of insertion tool for spring connection terminal blocks	1915
Screwless jumper bar assembly	1918

MARKERS

Entrelec offers easy to use marker card order forms

Custom markers	1941
Top marker continuous strip	1942
Printed circuit board markers	1944-1945

Full range of alphanumeric marker cards

For standard blocks	1928-1939
For 8 mm spring connection	1936
For 8 mm mini ADO insulation displacement	1936



To design custom markers on your PC, download entremark software. Contact Entrelec or log on to www.entrelec.com.

Accessories 13

Table of contents

ACCESSORIES

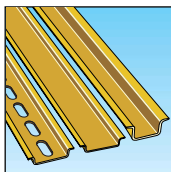

DIN RAILS
Pages 1895-1897

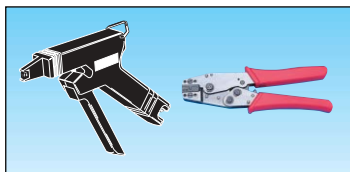

TOOLS
Pages 1900, 1915, 1924

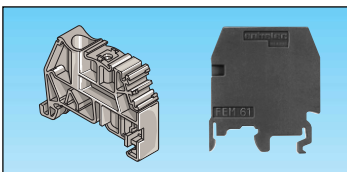

END STOPS/SECTIONS
Pages 1901-1905

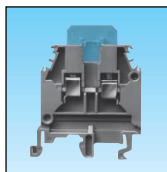

CIRCUIT SEPARATORS
Pages 1903-1904



TERMINAL BLOCK TEST CONNECTORS
Pages 1907-1913

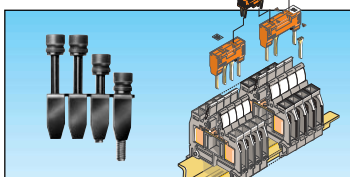

JUMPER BARS
Pages 1916-1919



FERRULES
Pages 1922-1924

See animated demo on www.entrelec.com.

MARKERS

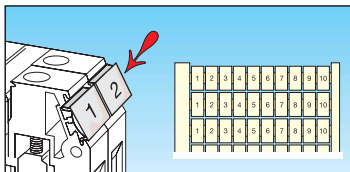

STANDARD MARKER CARDS
Pages 1928-1939

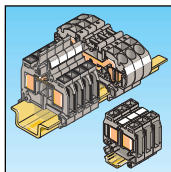

8 MM MINI ADO & SPRING CONNECTION MARKERS
Page 1936

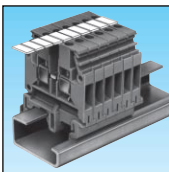

TOP MARKERS
Pages 1937-1938

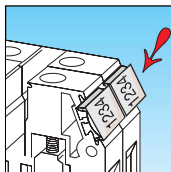

CUSTOM MARKING
Pages 1940-1945

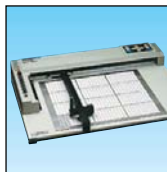

MARKER PLOTTER
Page 1940



PLOTTER SOFTWARE
Page 1940

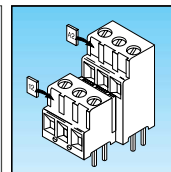

PCB TERMINAL BLOCK MARKING
Pages 1944-1945

ACCESSORIES

- Accessories, illustration 1894
- ADO, insulation displacement, tools 1900
- Bar, assembly 1909
- Brackets 1899
- Bridging plug 1920
- Circuit separators 1903-1904
- Connector, assembled, how to order 1913
- Connector assembly 1912-1913
- Connector, modular, terminal block 1907
- Connector plate 1920
- Connectors, assembly on
 - spring connection blocks 1914-1915
- Connectors, test 1908
- Cover, protective, plastic 1911
- Crimping tools, ferrule 1900, 1924
- Cutter, rail 1898
- DIN rails 1895-1897
- End sections 1902-1905
- End stops 1901
- Ferrule crimping tools 1900, 1924
- Ferrules 1922-1924
- Hand tools 1900, 1915, 1924
- Jumper bars 1916-1919
 - Insulation displacement jumper 1919
 - Comb type jumper 1919
 - Screw type jumper 1916-1918
 - Screwless jumper 1917-1918
- Label, protection 1920
- Modular connectors 1907

- Offset brackets, rail 1899
- Plug components 1909
- Rail cutter 1898
- Rail offset brackets 1899
- Rail tolerances 1897
- Rails 1895-1897
- Screwless end stops 1901
- Screwless jumper bars 1917-1918
- Separator, circuit 1903-1905
- Shield connector 1920
- Short-circuiting plug 1920
- Socket components 1910
- Spring connection tool, socket installation 1900
- Test connectors 1908
- Test plug 1906
- Test socket 1906
- Tools 1900, 1915, 1924
- Track, DIN rails 1895-1897
- Wire stripping tool 1900

MARKERS

- ADO insulation displacement marker cards,
 - 8 mm mini terminal blocks 1936
- Custom markers 1940-1945
 - Custom markers,
 - PC board terminal blocks 1944-1945
- Holders, marker 1947-1948
- Horizontal marking,
 - standard marker cards 1929-1932

- Marker cards 1928-1939
 - Mini ADO terminal blocks, 8 mm 1936
 - Pivoting 1938
 - Precut markers 1939
 - Spring connection terminal blocks, 8 mm 1936
 - Standard 1928-1935
 - Top marking 1937-1938
- Marker plotter 1940
- Markers, custom
 - PC board terminal blocks 1944-1945
 - Terminal blocks 1940-1942
- Marking methods, overview 1926-1927
- Order forms, custom markers 1941-1942, 1945
- Overview, marking methods 1926-1927
- PCB terminal block markers 1944-1945
- Plotter 1940
- Plotter software 1940
- Spring connection marker cards,
 - 8 mm terminal blocks 1936
- Top marking 1937-1938
- Vertical marking, standard marker cards 1933-1935

ADDITIONAL PRODUCTS

- Control and signaling switches 1950
- Cord connectors, strain relief, liquid-tight 1952
- DIN signaling units 1951
- Mosaic panel symbols 1951
- Pushbuttons 1950

Accessories

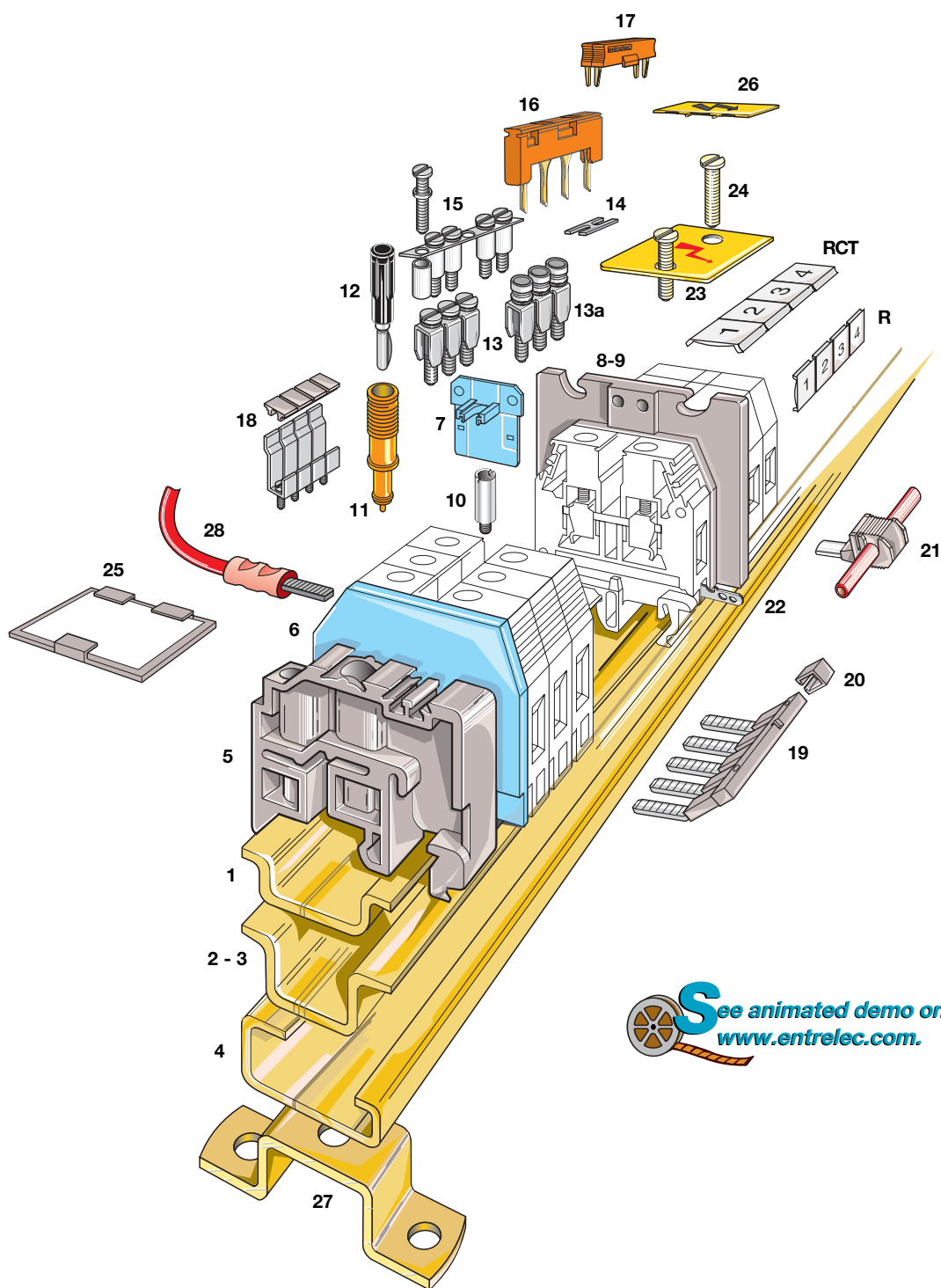

See animated demo on
www.entrelec.com

- | | | | | |
|-----|-------------------------------|------|------------------------------|-------------------------|
| 1 | Rail, DIN 3 (prepunched) | PR30 | Jumper bar not assembled | BJS |
| 2 | Rail, DIN 3 | PR4 | Screwless jumper bar | BJE |
| 3 | Rail, (prepunched) | PR5 | Screwless bridge | BJB |
| 4 | Rail, DIN 1 | PR1 | Alternated jumper bar | BJA |
| 5 | End stop | BA | Comb type jumper bar | PC |
| 6 | End section | FE | Insulating comb tip | EIP |
| 7 | Circuit separator | SCM | IDC jumper | AD |
| 8 | Separator end section (block) | SCF | Shield connector | CB |
| 9 | Separator end section (rail) | SCF | Protection label | EP |
| 10 | Test socket | AL | Screw for protection label | VSP |
| 11 | Test device | DC | Marker-holder for end stop | PEB |
| 12 | Test plug | FC | Single pole protection label | EPU |
| 13 | Assembled jumper bar not IP20 | BJM | Bracket | TS |
| 13a | Assembled jumper bar IP20 | BJMI | Ferrule | |
| 14 | Connector plate | EL | Markers (sides of blocks) | |
| | | | RCT | Markers (top of blocks) |

Mounting rails Symmetrical - DIN 3

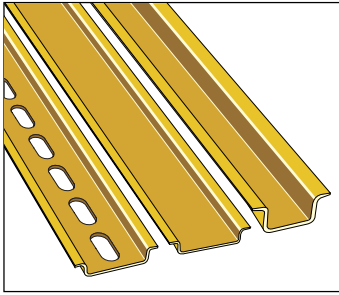

These rails are often used as grounding bars. The current carrying capacity of these rails and the copper wire sizes required to carry that current are given below.

Rail	Material	RAIL CURRENT CARRYING CAPACITY	
		Current (A)	Wire size AWG mm ²
TS 35/F6	Steel	65	8 10
TS 35	Steel	87	6 16
TS 35/S	Steel	87	6 16
TS 35	Aluminum	265	000 95
TS 35	Copper	150	0 50
TS 35	Plastic	0	

All rails are in compliance with EN 50022 standard (DIN 46277-3 - NFC 63015) DIN 3.

Tolerances are ± unless otherwise noted.

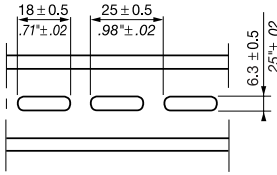
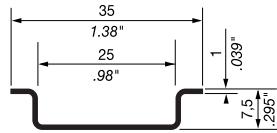
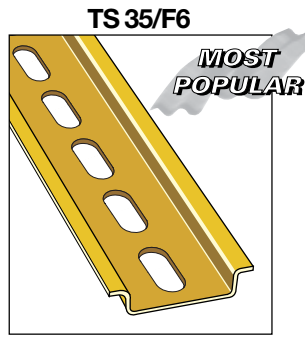

Type	P/N
------	-----

PR30 (TS 35/F6) 0173 220.05
Zinc bichromate plated steel, prepunched length 2 m 6'6" (78") approx. The length and prepunched cut out dimensions are approximate.

PR30 (TS 35/F6) 0101 508.04
Length 1 m 3'3" (39") approx.

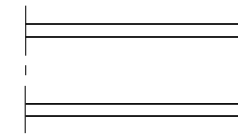
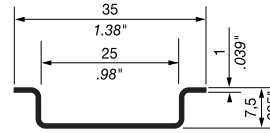
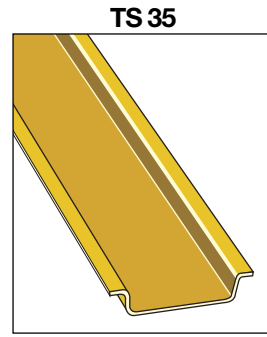

Type	P/N
------	-----

PR3.Z2 (TS 35) 0174 300.17
Zinc bichromate plated steel. Length 2 m 6'6" (78") approx.

PR3.Z2 (TS 35) 0101 513.10
Length 1 m 3'3" (39") approx.

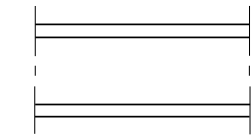
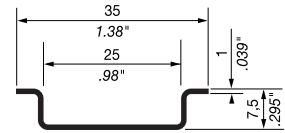
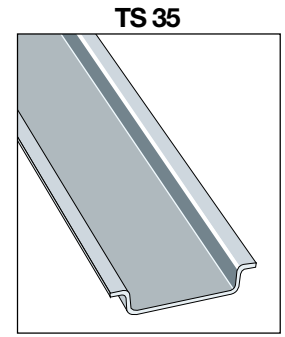

Type	P/N
------	-----

PR3.G2 (TS 35) 0177 170.07
White, passivated galvanized steel. Length 2 m 6'6" (78") approx.

PR3.G2 (TS 35) 0101 514.11
Length 1 m 3'3" (39") approx.

TS 35/S

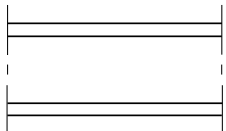
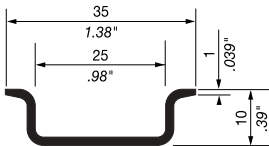
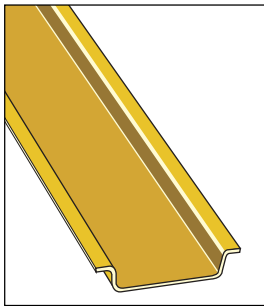

Type	P/N
------	-----

PR3.10 (TS 35/S) 0101 597.15
Zinc bichromate plated steel. Height 10 mm (0.39"), length 2 m 6'6" (78") approx.

PR3.10 (TS 35/S) 0101 512.17
Length 1 m 3'3" (39") approx.

TS 35 Aluminum Rail

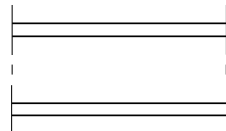
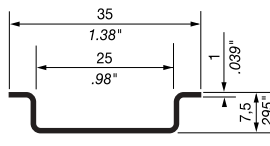
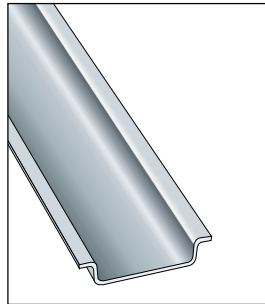

Type	P/N
------	-----

PR3.AL (TS 35) 0101 589.25
Aluminum rail. Length 2 m 6'6" (78") approx.

PR3.AL (TS 35) 0101 500.24
Length 1 m 3'3" (39") approx.

TS 35 Copper Rail

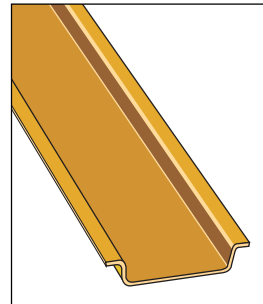

Sold in North America only.

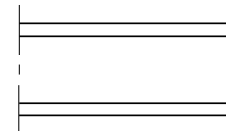
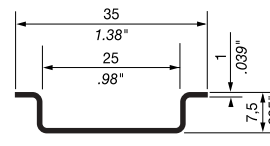

Type	P/N
------	-----

PR3.CU (TS 35) 0101 592.10
Copper rail. Length 2 m 6'6" (78") approx.

PR3.CU (TS 35) 0101 595.13
Length 1 m 3'3" (39") approx.

TS 35 Plastic Rail

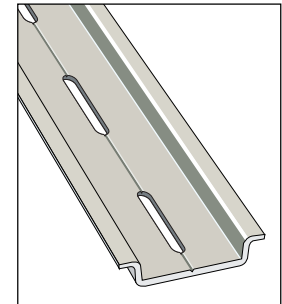

Sold in North America only.
Rail material UL94 V0

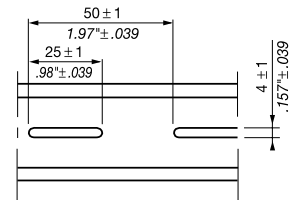
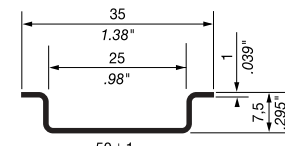

Type	P/N
------	-----

PR3.PL (TS 35) 0101 573.24
Plastic rail, prepunched length 2 m 6'6" (78") approx. The length and prepunched cut out dimensions are approximate.

PR3.PL (TS 35) 0101 572.23
Length 1 m 3'3" (39") approx.

Mounting rails Symmetrical - DIN 3

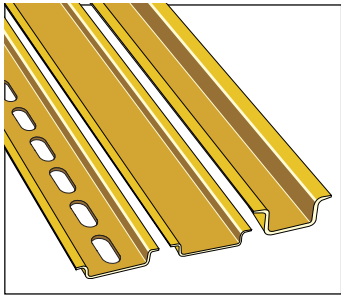

These rails are often used as grounding bars. The current carrying capacity of these rails and the copper wire sizes required to carry that current are given below.

RAIL CURRENT CARRYING CAPACITY

Rail	Material	Current (A)	Wire size AWG	Wire size mm ²
TS 35/CF6	Steel	125	4	25
TS 35/C1	Steel	143	2	35
TS 35/C	Steel	125	4	25
TS 35/C ALU	Aluminum	265	000	95
High rail 90°	Steel	65	8	10
High rail 30°	Steel	65	8	10

All rails are in compliance with EN 50022 standard (DIN 46277-3 - NFC 63015) DIN 3.

Tolerances are ± unless otherwise noted.

TS 35/CF6

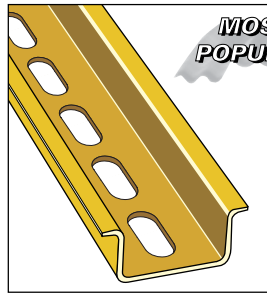

MOST POPULAR

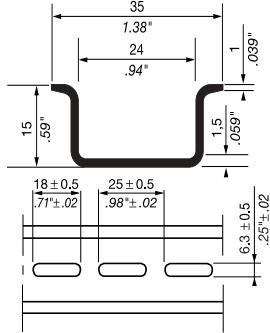

Type	P/N
------	-----

PR5 (TS 35/CF6) 0101 598.26

Zinc bichromate plated steel, prepunched length 2 m 6'6" (78") approx. The length and prepunched cut out dimensions are approximate.

PR5 (TS 35/CF6) 0101 509.05

Length 1 m 3'3" (39") approx.

TS 35/C1

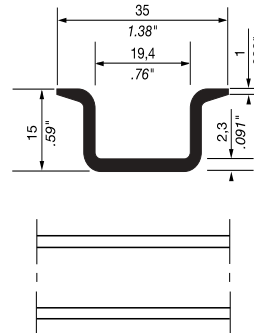
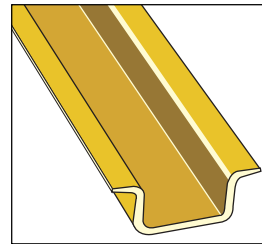

Type	P/N
------	-----

PR4 (TS 35/C1) 0168 500.12

Zinc bichromate plated steel. Length 2 m 6'6" (78") approx.

PR4 (TS 35/C1) 0101 517.14

Length 1 m 3'3" (39") approx.

TS 35/C

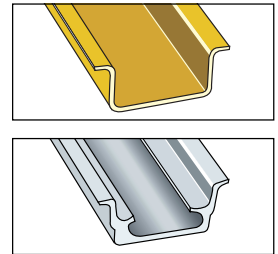

TS 35/C ALU

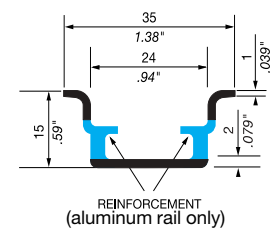

REINFORCEMENT (aluminum rail only)

Type	P/N
------	-----

PR5 (TS 35/C) 0168 700.22

Zinc bichromate plated steel. Length 2 m 6'6" (78") approx. Length 1 m 3'3" (39") approx.

PR5.A2 (TS 35/C ALU) 0101 502.26

Reinforced aluminum. Length 2 m 6'6" (78") approx. Length 1 m 3'3" (39") approx.

TS 35, High Rail 90°

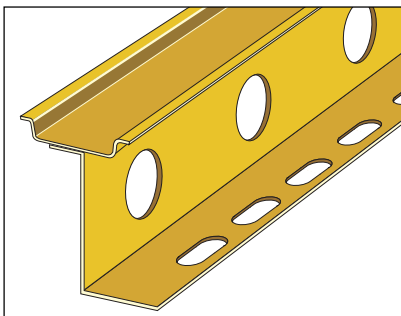

Sold in North America only.

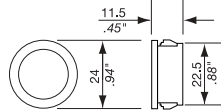

Insert for rail knockout:

Open grommet, black 0106 064.26
Closed blind plug, black 0106 083.12

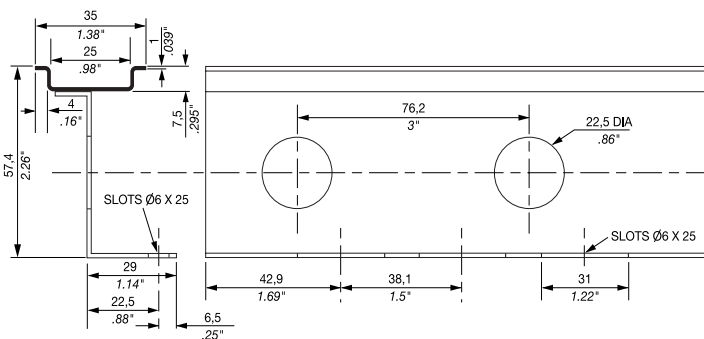

Type	P/N	Type	P/N
------	-----	------	-----

PR3.Z2 HR90 0101 571.02

Zinc bichromate plated steel, prepunched length 2 m 6'6" (78") approx. The length and prepunched cut out dimensions are approximate.

PR3.Z2 HR90 0101 570.01

Zinc bichromate plated steel. Length 1 m 3'3" (39") approx.

TS 35, High Rail 30°

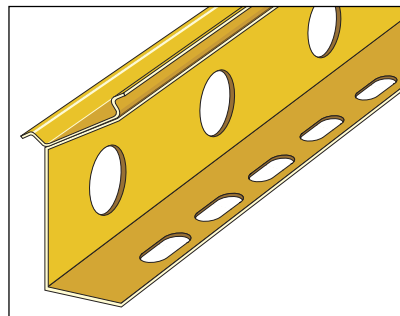

Sold in North America only.

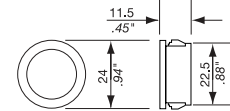

Insert for rail knockout:

Open grommet, black 0106 064.26
Closed blind plug, black 0106 083.12

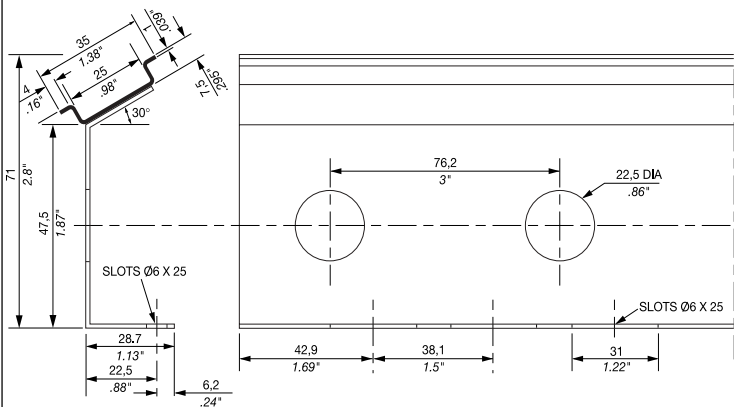

Type	P/N	Type	P/N
------	-----	------	-----

PR3.Z2 HR30 0101 875.23

Zinc bichromate plated steel, prepunched length 2 m 6'6" (78") approx. The length and prepunched cut out dimensions are approximate.

PR3.Z2 HR30 0101 874.22

Zinc bichromate plated steel. Length 1 m 3'3" (39") approx.

Mounting rails Asymmetrical - DIN 1 Symmetrical - DIN 2

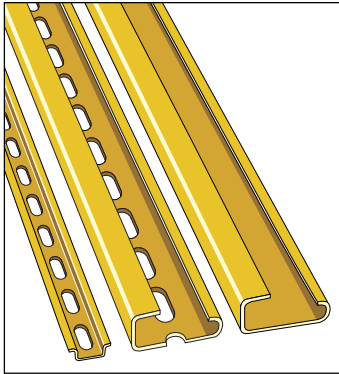

The "Series 5000" terminal blocks snap onto the PR1 asymmetrical DIN 1 rails described here.

The "Series DR" terminal blocks snap onto the PR2 symmetrical DIN 2 rail described here.

These rails are often used as grounding bars. The current carrying capacity of these rails and the copper wire sizes required to carry that current are given below.

Rail	Material	Current (A)	Wire size AWG	mm ²
TS 32	Steel	143	2	35
TS 32 ALU	Aluminum	265	000	95
TS 32/F6	Steel	100	4	25
TS 15/F	Steel	35	12	4
TS 15	Steel	47	10	6

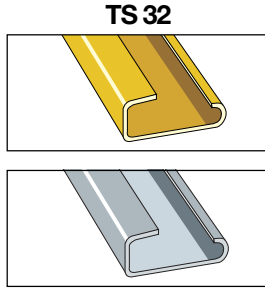

TS 32 ALU

Asymmetrical 32 mm 1.26" G rail in compliance with EN 50035 standard (DIN 46277-1 - NFC 63018) DIN 1

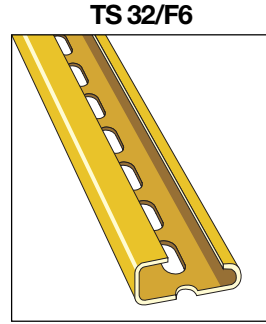
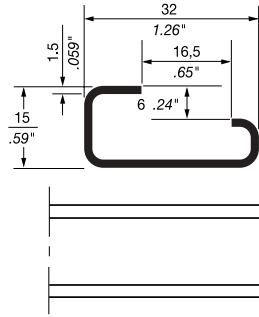

Asymmetrical 32 mm 1.26" G rail in compliance with EN 50035 standard (DIN 46277-1 - NFC 63018) DIN 1

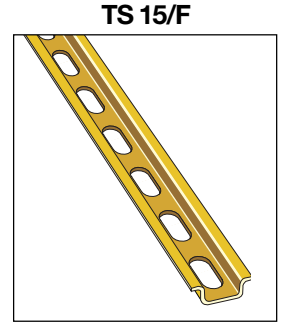
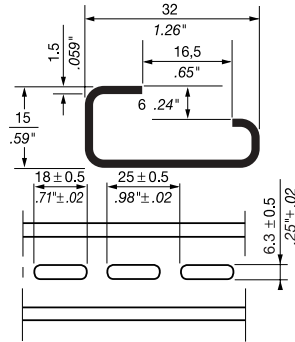

Symmetrical rail 15 mm .59" in compliance with EN 50045 standard (DIN 46277.2)

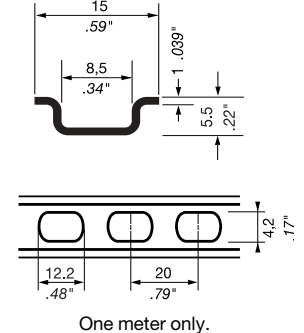

One meter only.

Type	P/N	Type	P/N	Type	P/N
PR1.Z2 (TS 32)		PR1 (TS 32/F6)		PR2 (TS 15/F)	0101 673.00
Zinc bichromate plated steel.		Prepunched zinc bichromate plated steel.		Prepunched zinc bichromate plated steel.	
Length 2 m 6'6" (78") approx.	0163 050.04	Length 2 m 6'6" (78") approx.	0101 501.25	Length 1 m 3'3" (39") approx.	
Length 1 m 3'3" (39") approx.	0101 596.14	Length 1 m 3'3" (39") approx.	0101 511.16		
PR1.A2 (TS 32 ALU)				PR2 (TS 15)	0101 674.01
Aluminum alloy				Zinc bichromate plated steel.	
Length 2 m 6'6" (78") approx.	0167 120.23			Not prepunched.	
Length 1 m 3'3" (39") approx.	0101 603.07			Length 1 m 3'3" (39") approx.	

Rail tolerances

Symmetrical - DIN 3

Rail length: supplied in lengths of 1 or 2 meters or in custom cut lengths. Allow 3 mm for the rail cutting blade thickness.

Shown for DIN rails 35 mm wide and either 7.5 mm or 15 mm high. For other rail tolerances, contact Entrelec.

Dimensions apply over the whole length of the DIN rail, but shall not be verified anywhere less than 10 mm from the ends.

All dimensions in millimeters.

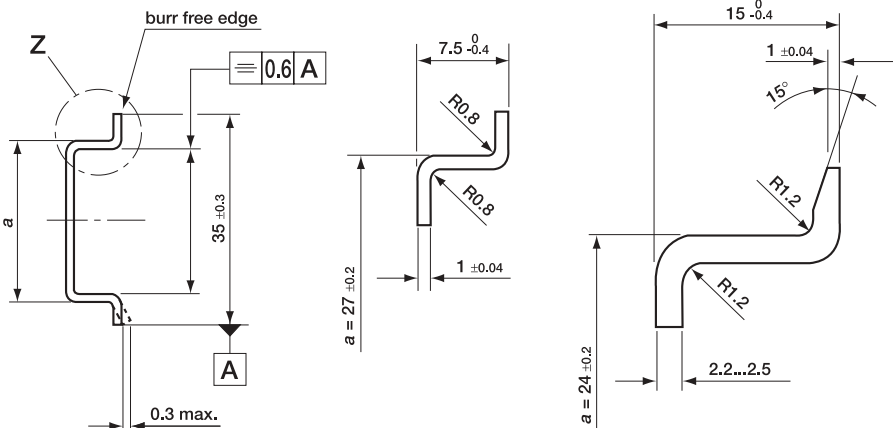

Asymmetrical - DIN 1

Rail length: supplied in lengths of 1 or 2 meters or in custom cut lengths. Allow 3 mm for the rail cutting blade thickness.

Shown for DIN 1 rails 32 mm wide and 15 mm high.

Dimensions apply over the whole length of the DIN rail, but shall not be verified anywhere less than 10 mm from the ends.

All dimensions in millimeters.

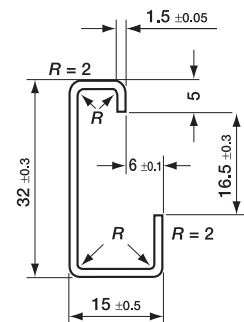

Rail cutter - Single interchangeable die

Model	Description	P/N
ALC 01 S	Manual rail cutter (order dies separately)	0360 004.28
ALC 32	Cutting die for TS32 DIN 1 rail	0329 030.06
ALC 35	Cutting die for TS35 DIN 3 low rail	0329 031.23
ALC 35C	Cutting die for TS35C DIN 3 high rail	0329 032.24
ALC 15	Cutting die for TS15 DIN 2 rail	0329 033.25
ALC 1	Rail guide	0329 034.26

Low cost, bench top rail cutter for a single rail die for manually cutting DIN rails to custom lengths. Tool is intended for use where only one type of DIN rail profile is usually cut. Four standard rail dies are available which may be manually interchanged in the tool. Guide plate facilitates insertion of rails and provides rail support. Length indicator rod calibrated for easy and direct reading. Tool requires only minor assembly of 1 meter (39.4") handle, die, length indicator rod, and end-stop plate. Cuts both standard and nonstandard rail materials. Tool may be used to punch 6.3 mm x 13 mm (approx. 1/4 x 1/2 inch) openings at any position on the axis of the rail. Easily portable.

- Interchangeable dies for cutting/punching various rail sizes
- Simple assembly and operation
- Base plate for bench mounting
- Optional rail guide and rail stop
- Direct reading rail length indicator (with rail guide)
- Instruction booklet and mounting keys

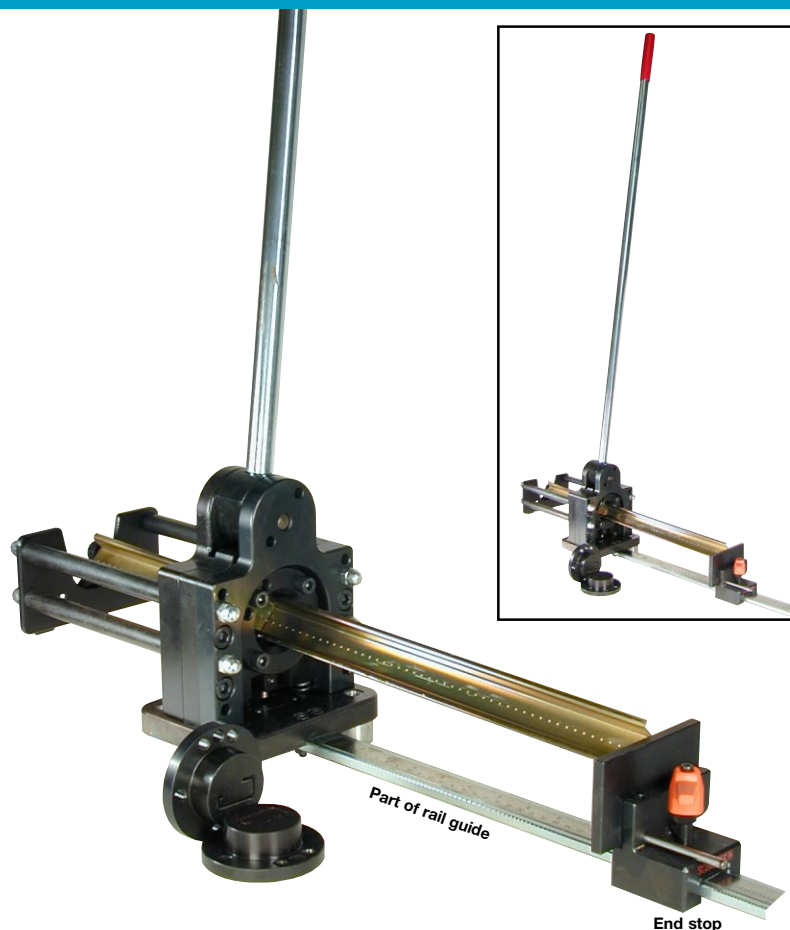

Rail cutter - Four built-in dies

Model	Description	P/N
A3001	Rail cutter, 4 rails, manual	0306 454.02
A3001H	Rail cutter, 4 rails, hydraulic	XUS0 004.65

No additional accessories required.

Bench top rail cutter with four built-in dies for manual or hydraulic cutting of DIN rails to custom lengths. Tool is intended for use where multiple DIN rail profiles are to be cut without changing the die. Unit accommodates four types of rails: DIN 1, DIN 2, DIN 3 Low, and DIN 3 High. Tool comes complete with rail guides and no additional accessories are required. Guide plate facilitates insertion of rails and provides rail support. Length indicator rod calibrated for easy and direct reading. Tool requires only minor assembly of 1 meter (39.4") handle, die, length indicator rod, and end-stop plate and is easily portable. Cuts both standard and non-standard rail materials. Tool may be used to punch 6.3 mm x 13 mm (approx. 1/4 x 1/2 inch) openings at any position on the axis of the rail.

- Four built-in dies for cutting/punching various rail sizes
- Simple assembly and operation
- Base plate for bench mounting
- Rail guide and rail stop included
- Direct reading rail length indicator
- Instruction booklet and mounting keys.

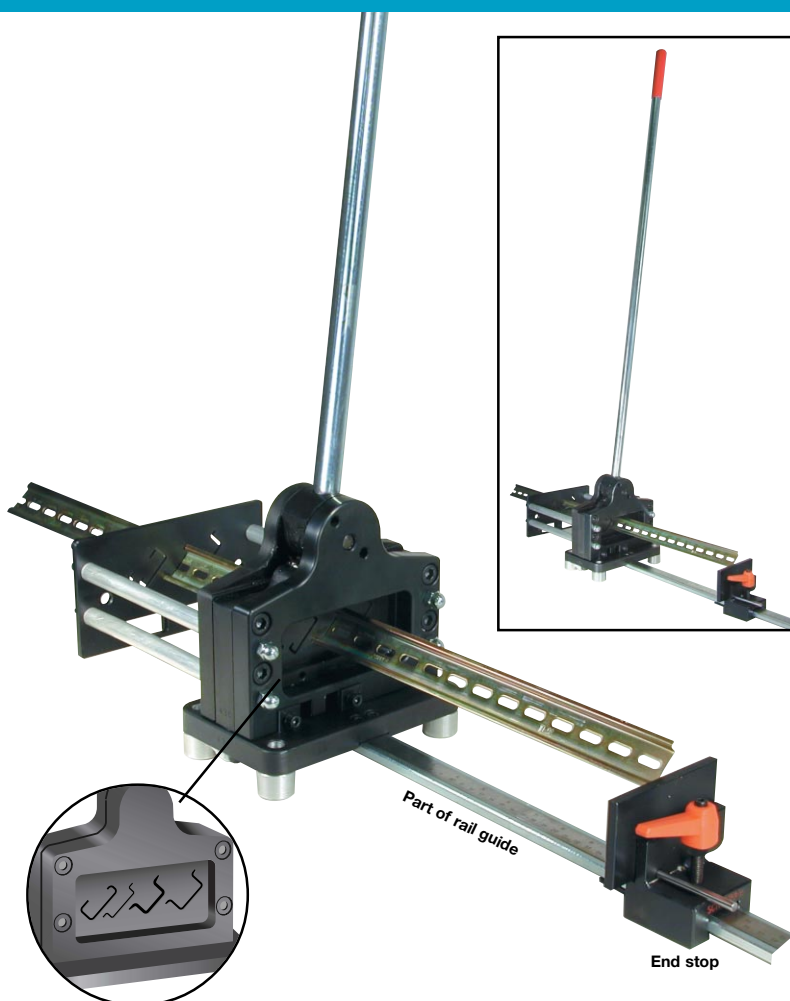

Rail offset brackets, angled

Zinc bichromate plated steel

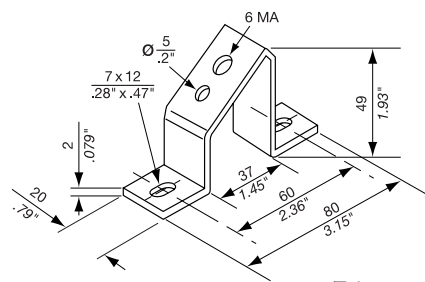

(Tolerance ±2 mm, ±0.08 in)

TS4-SM6 0306 022.24

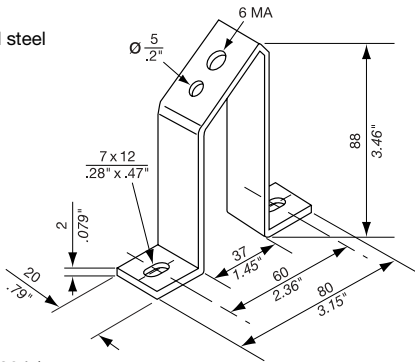

TS8-SM6 0306 023.25

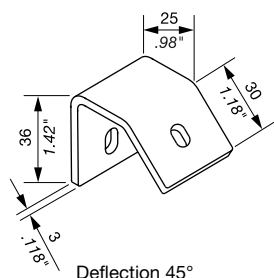
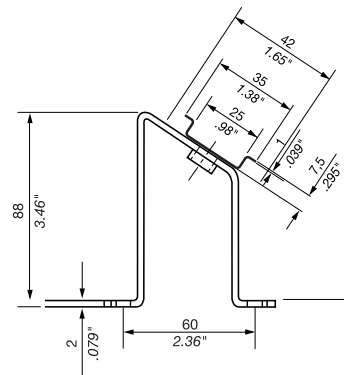

TS.45 0008 521.26

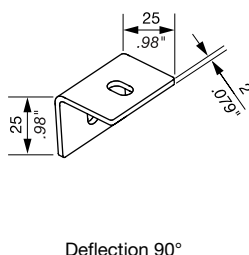

TS.90 0008 520.01

DIN rail spacer/isolator

Ceramic style spacer isolates a DIN rail from the chassis. Brass threaded inserts, at each end of the isolator, allow you to screw attach the isolator to the chassis and DIN rail.

Height		P/N
mm	in	
20	0.79	0106 393.20
25	0.98	0106 394.25
30	1.18	0106 395.30
40	1.57	0106 396.40
50	1.97	0106 397.50
60	2.36	0106 398.60
70	2.76	0106 399.75

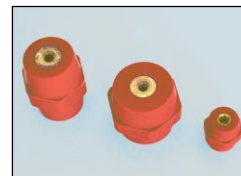

Rail offset brackets, vertical offset

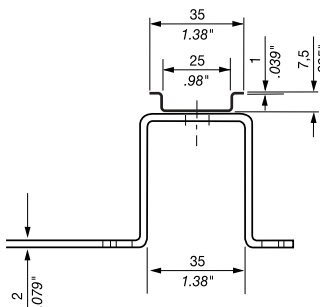
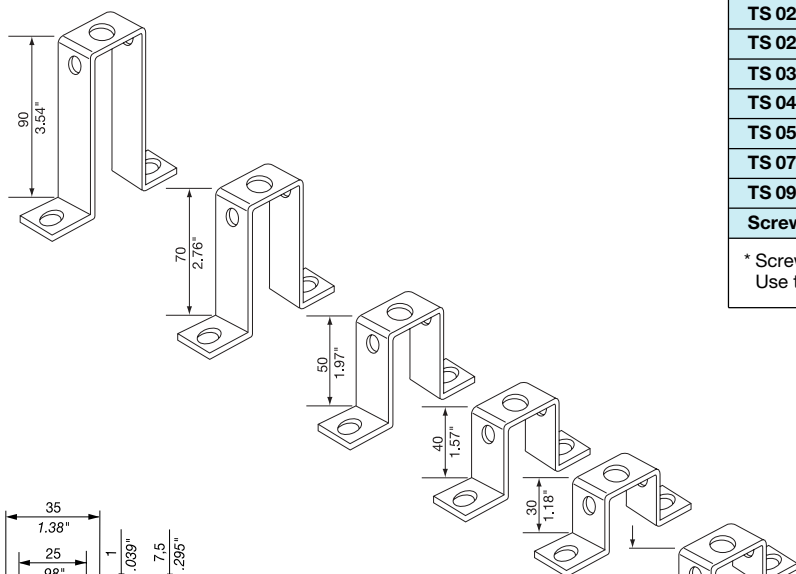

Top mounted rail

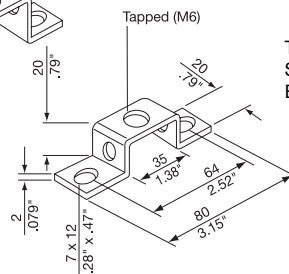

Tapped (M6)
Top hole tapped (M6)
Side holes unthreaded
Bottom mounting holes oblong

Type	Height		Old P/N	New P/N
	mm	in		
TS 0201-SM6	20	0.79	304 200.26	0101 653.04
TS 0251-SM6	25	0.98	N/A	0101 930.22
TS 0301-SM6	30	1.18	N/A	0101 654.05
TS 0401-SM6	40	1.57	304 201.13	0101 655.06
TS 0501-SM6	50	1.97	N/A	0101 656.07
TS 0706-SM6	70	2.76	304 202.14	0101 657.00
TS 0904-SM6	90	3.54	304 203.15	0101 658.11
Screw SM6*			304 234.03	0101 659.12

* Screw for bracket is flat head, allen key.
Use this screw to mount rail to bracket.

Tools

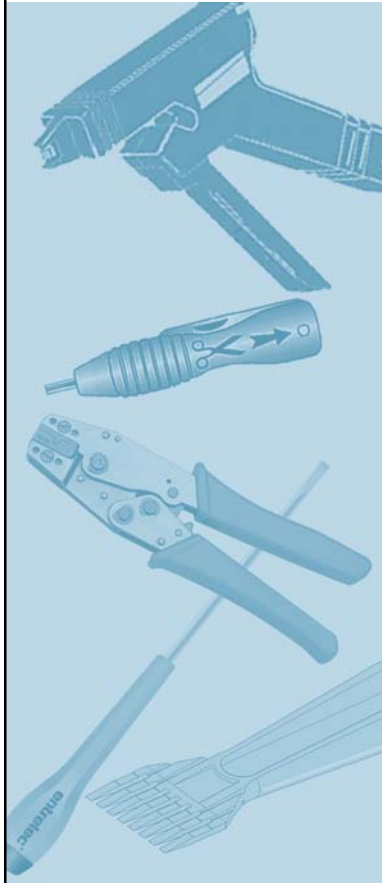

A.D.O. pneumatic tool kit



Type	P/N
OUTAD	0205 710.11
Pneumatic tool kit	
OUTA	0205 284.03
Replacement head kit	

Hand tool operated by compressed air for repetitive attachment of wire into ADO connections. Insert tool head into ADO terminal and operate handle to activate connection cycle. Easy access and attachment of compressed air line to the ADO tool through a quick-release coupling. A highly reliable connection tool which eliminates operator fatigue. Includes wire extraction tool.

See Section 1, ADO Insulation Displacement Blocks, for further details.

A.D.O. semi-automatic tool

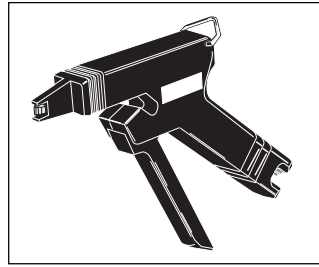

Type	P/N
OUPAD	0178 944.04
Semiautomatic tool	
OUTA1	0178 942.02
Standard head	
OUTA2	0179 676.10
Head - double deck blocks	

Tool for connecting wire to ADO terminal blocks. Single, high speed connection. Insert wire into ADO terminal, position tool, and pull trigger. Simplifies wiring, reduces operator fatigue while ensuring high reliability connection.

See Section 1, ADO Insulation Displacement Blocks, for further details.

A.D.O. hand tool

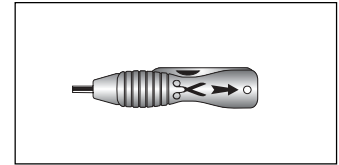

Type	P/N
OUMAD	0179 466.06

Use with ADO terminal blocks for manual insertion or extraction of wire. Insert wire into block, place tool in upper block opening, and push wire into block. Shaped for ease of handling and precise wire insertion.

See Section 1, ADO Insulation Displacement Blocks, for further details.

Ferrule crimping tools



Heavy duty industrial grade crimping tool.

Ferrule wire range	P/N
28 to 10 AWG	0304 439.01
14 to 8 AWG	0304 440.16



All purpose economy crimping tool.

Ferrule wire range	P/N
22 to 10 AWG	0305 626.05
10 to 6 AWG	0305 627.06

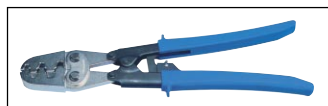

Heavy duty industrial grade crimping tool.

Ferrule wire range	P/N
8 to 1 AWG	0304 441.03

Wire stripping tool



Wire strip range	P/N
20 to 10 AWG	XUS0 003.71

Fast and easy-to-operate wire stripper that needs no adjustment and will not damage solid or stranded wire. Ideal for use in any control or low voltage wire stripping applications for wire sizes from 20 AWG to 10 AWG (0.5 mm² to 6 mm²). Stripping blades are replaceable with expected operating life in excess of 100,000 operations. Includes wire cutter and adjustable wire stop for consistent length of stripping.

Tool for installing sockets in spring connection terminal blocks

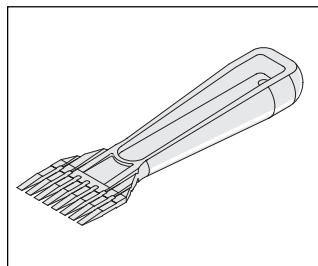

Type	P/N
2 poles	0299 982.25
3 poles	0299 983.26
4 pole	0299 984.27
5 poles	0299 985.20
6 poles	0299 986.21
7 poles	0299 987.22
8 poles	0299 988.03

Tool to insert sockets into spring connection terminal blocks. Fingers of tool are inserted into the terminal block and act as levers to open the spring connection mechanism. After sockets are inserted, tool is easily withdrawn. For use in sockets of 1 to 8 poles. Factory mounting of sockets onto terminal blocks of 9 poles or more is recommended. Consult Entelec.

Screwdrivers

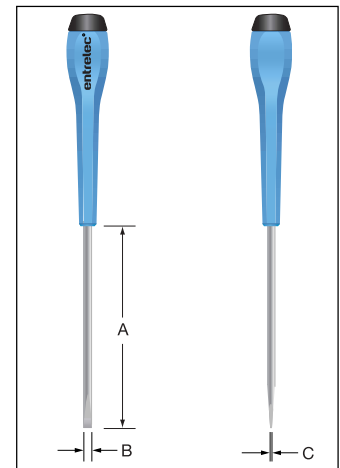

A (mm)	B (mm)	C (mm)
Shaft Length	Tip Width	Tip Cross Section
65	2.0	0.4
100	3.5	0.6
125	5.5	1.0
150	6.5	1.2

Tip Width, mm	P/N
2	0101 696.20
3.5	0101 697.21
5.5	0101 698.02
6.5	0101 699.03
Package of 4	0101 695.27

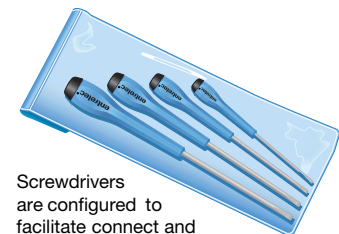

Screwdrivers are configured to facilitate connect and disconnect of wire in screw clamp terminal blocks. Nonbreakable tip for long life. Tapered shank and rotating top provides operator comfort during repetitive use. Designed for precise screw slot fit for all screw clamp terminal block connections. Screwdrivers may be ordered separately or as a package of four (4).

BA

End stops

The end stops are mounted at the extremity of the terminal board assembly, giving additional support to the terminal blocks as markers. For various types of marking, refer to the marker section.

BADL

Screwless, snaps on rail without tool. V0 grey polyamide for DIN 3 rail. Maintained in place and locked on the rail with metal grips.

To reposition, do not slide on the rail. Withdraw and snap again (screwdriver DIA. 6,5 mm .256" max.)

Thickness: 9 mm .354"

BADL grey **0199 408.02**

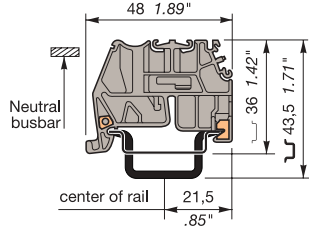
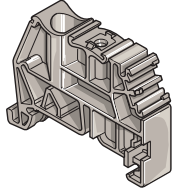

BAM

Multi-rail end stop of grey V2 or V0 polyamide equipped with 2 blocking screws allows mounting on PR1, PR3, PR4 and PR5 (DIN 1, DIN 3) rails.

Recommended screwdriver: DIA. 5,5 mm .217"

Recommended torque:

Min. 0,8 mN - Max. 1 mN

Min. 7.1 lb.in - Max. 8.9 lb.in

Thickness: 9,1 mm .358"

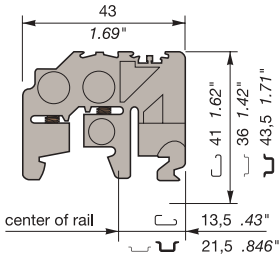
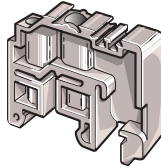

BAM grey **0103 002.26**

BAM V0 beige **0199 306.03**

BAMH

Multi-rail end stop of V2 or V0 polyamide equipped with 2 blocking screws allows mounting on PR1, PR3, PR4 and PR5 (DIN 1, DIN 3) rails.

Suitable for double deck blocks.

Recommended screwdriver:

DIA. 5,5 mm .217"

Recommended torque:

Min. 0,8 mN - Max. 1 mN

Min. 7.1 lb.in - Max. 8.9 lb.in

Thickness: 9,1 mm .358"

BAMH grey **0114 836.00**

BAMH V0 beige **0194 836.01**

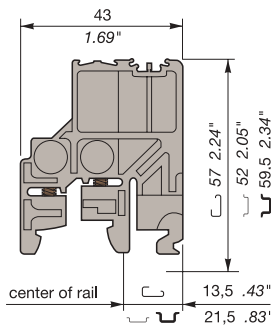

BAR

Reversible end stop of beige polyamide with blocking bracket. To be mounted vertically or at a 30° angle, on PR1 rail only.

Thickness: 10 mm .394"

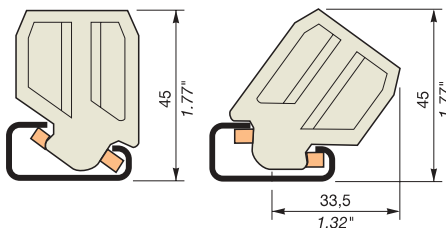

BAR beige **0164 519.24**

BADH, BAEH

Tall end stop of polyamide, for use with M 70/22, M 95/26 blocks, power blocks, double or triple deck blocks, and electronic interface modules series 7 000, 8 000, 10 000, 11 000 and 30 000.

Snaps on rail - Easy mounting and repositioning, even between 2 blocks.

Recommended screwdriver: DIA. 5,5 mm .217"

Recommended torque: Min. 1,2 Nm - Max. 1,4 Nm

Min. 10.6 lb.in - Max. 12.3 lb.in

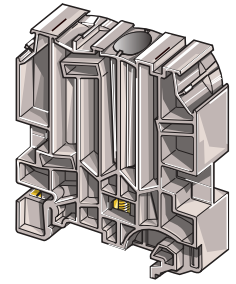

Thickness: 12 mm .472"

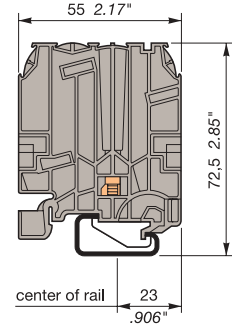
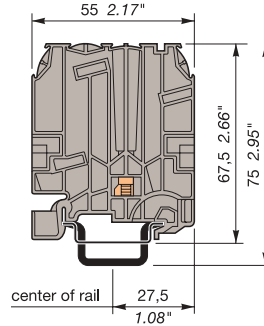

BADH grey **0116 900.27**

BAEH grey **0116 934.04**

BAEH beige **0196 934.05**

BADRL

End stop of V0 grey polyamide snaps on DIN 2 rail, automatically maintained in place with metal grips.

To reposition, do not slide on the rail. Withdraw and snap again (screwdriver DIA. 4 mm .157" max.)

Thickness: 6,5 mm .256"

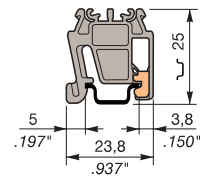
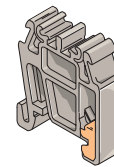

BADRL grey **0199 420.21**

BAH11



To be mounted on symmetrical rail type 1 12,2 x 5,1 mm .480 x .201", according to NFC 93 461 standard.

Thickness: 7,1 mm .280"

BAH11 **0164 659.10**

BAH21



To be mounted on strengthened symmetrical rail type 2 only: 21,8 x 8,2 mm .858 x .323", according to NFC 93 461 standard.

Thickness: 7,1 mm .280"

BAH21 **0167 489.22**

BAH22

To be mounted on strengthened symmetrical rail type 2 only 21,8 x 8,2 mm .858 x .323", according to NFC 93 461 standard.

Thickness: 7,1 mm .280"

BAH22 **0164 655.04**



BAH24

To be mounted on strengthened symmetrical rail type 2 only 21,8 x 8,2 mm .858 x .323", according to NFC 93 461 standard.

Thickness: 7,1 mm .280"

BAH24 **0168 355.13**



FE End sections

When assembled on the mounting track, terminal blocks cover each other's open side. At the end of an assembly, or when the size of the blocks change in an assembly, an end section must be used to isolate the open side of the block. End sections are available for all terminal blocks and are sometimes available in colors. Colored end sections can offer an easy and economical way to separate circuits for identification.

Snap-on end sections for blocks

End sections below are aligned with the profile of the block and snap on the open side of the block.

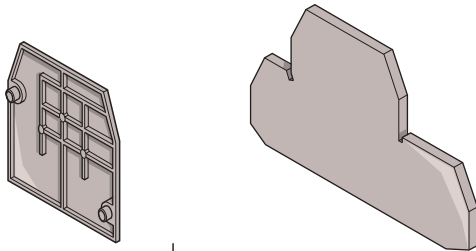

Type	Thickness	Color	P/N
Blocks			
FEM6	2,8 mm .110"		
MA 2,5/5 except D	grey		0118 368.16
M 4/6 except D and G	white		0103 312.20
M 4/6...	blue		0128 368.10
M 4/6.H and M1	yellow		0103 062.21
M 1,5/6.HH and ADV	green		0103 125.15
MTC 6	orange		0103 126.16
M 6/8 and M 10/10	black		0107 005.25
FEMS6	3 mm .118"		
MS 4/6...	grey		0113 885.01
	blue		0123 885.03
	yellow		0103 300.11
	orange		0103 292.25
FEMS8	3 mm .118"		
MS 6/8...	grey		0114 195.06
	blue		0124 195.00
	yellow		0103 301.06
	orange		0103 302.07
FEM3A	3 mm .118"		
M 4/6.3A	grey		0116 576.15
	blue		0126 576.17
	yellow		0103 862.20
FEM4A	3 mm .118"		
M 4/6.4A	grey		0116 629.22
M 4/6.SNBT.4A	blue		0126 629.24
	yellow		0103 863.21
FEM6D	1 mm .039"		
MA 2,5/5.D	grey		0118 499.23
M 4/6.D	blue		0128 499.25
M 4/6.D2.H			
M 1,5/6.D2.HH			
M 4/6.D2.M			
FEM61D	3 mm .118"		
M 4/6.D2.G and 2G	grey		0114 815.03
FEM62	3 mm .118"		
M 4/6.SB	grey		0114 994.07
M 4/6.SNB	orange		0103 612.25
FEM62D	3 mm .118"		
MS 4/6.D2.2G	grey		0114 429.10
FEM6G	2,5 mm .098"		
M 2,5/6.2G	grey		0113 027.07
M 4/6.G and 2G	blue		0123 027.01
FEM8	3 mm .118"		
M 6/8.S and SB	grey		0113 373.26
M 6/8.SN	orange		0103 230.02
FEM8D2S	1,5 mm .059"		
M 4/8.D2.SF	grey		0116 913.07
FEM8S	1,5 mm .059"		
M 4/8.SF	grey		0116 951.15
M 4/8.SN	orange		0103 923.15
M 4/8			
FEM9	3 mm .118"		
M 6/9.EE	grey		0113 067.17
FEM12	3 mm .118"		
M 16/12	grey		0118 618.01
	blue		0128 618.03
	yellow		0103 065.24

Type	Thickness	Color	P/N
Blocks			
FEM12F	3 mm .118"		
M 6/12.FF	white		0114 023.04
FEM12N	1 mm .039"		
M 16/12.NT	blue		0128 616.21
FEM12S	3 mm .118"		
MB 10/12.SF	grey		0117 628.22
FEM13U	1,5 mm .059"		
ML 10/13.SF	black		0199 635.24
ML 10/13.SN			
MU 10/13.SF			
FEM13F	1 mm .039"		
M 6/13.FF	grey		0116 977.17
FEM16	3 mm .118"		
M 35/16	grey		0118 233.27
	blue		0128 233.21
	yellow		0103 061.20
FEM22	3 mm .118"		
M 70/22	grey		0113 065.15
	yellow		0103 881.14
FEMG	1,5 mm .059"		
M 4/6.3G	grey		0114 144.12
M 4/6.5.3G			
M 2,5/6.4G			
M 2,5/6.5.4G			
FEMR10	2,5 mm .098"		
M 10/10.RS	grey		0114 434.05
FEMT1	2,8 mm .110"		
M 6/8.STP	grey		0113 137.02
FEMT2	1 mm .039"		
M 6/8.ST	grey		0113 629.27
FEMT3	2,5 mm .098"		
M 4/6.ST	grey		0114 328.22
FEMT4	3 mm .118"		
M 6/8.STA	grey		0114 778.05
FEMSTA	3 mm .118"		
M 6/8.STA	grey		0116 979.21
FEMR8	2,8 mm .110"		
M 6/8.RS	grey		0116 987.02
FEMR8T	2,8 mm .110"		
M 6/8.STP.RS	grey		0116 991.06
FEM8D1	1 mm .039"		
M 6/8.D...	grey		0116 656.25
FEM8D2	4 mm .157"		
M 6/8.D...	grey		0116 657.26
FEM12N	1 mm .039"		
M 16/12.NT	blue		0128 616.21
FEMS6D	1 mm .039"		
M 4/6.D2.SNBT	grey		0116 591.05
FEMT5	2,5 mm .098"		
M 10/10.St.Sn	grey		0116 781.13
FED3E	3 mm .118"		
D 2,5/6.D	grey		0116 771.20
FED6	1 mm .039"		
D 4/6...	grey		0116 964.12
FEDA6	1 mm .039"		
D 4/6.A...	grey		0116 965.13

End sections V0

Type	Thickness	Color	P/N
Blocks			
FEM3AP V0	3 mm .118"		
M 4/6.3A.P V0	yellow		0199 876.26
FEM4AP V0	3 mm .118"		
M 4/6.4A.P V0	yellow		0199 879.01
FEM6 V0	2,5 mm .098"		
M 4/6 V0	beige		0198 368.17
M 6/8 V0	blue		0199 302.07
M 10/10 V0	yellow		0199 305.02
MA 2,5/5 V0			
FEM3A V0	3 mm .118"		
M 4/6.3A V0	beige		0196 576.16
FEM4A V0	3 mm .118"		
M 4/6.4A V0	beige		0196 629.23
M 4/6.SNBT.4A V0			
FEM62 V0	3 mm .118"		
M 4/6.SB V0	beige		0194 994.00
FEM6D V0	1 mm .039"		
M 4/6.D V0	beige		0198 499.24
MA 2,5/5.D2 V0			
FEM6G V0	2,5 mm .098"		
M 2,5/6.2G.2G V0	beige		0193 027.00
M 4/6.2G V0			
FEM8 V0	3 mm .118"		
M 6/8.S V0	beige		0193 373.27
M 6/8.SN V0			
FEMT3 V0	2,5 mm .098"		
M 4/6.ST	beige		0194 328.23
FEM8D2S V0			
M 4/8.D2.SF	beige		0196 913.00
FEMR8 V0	2,8 mm .110"		
M 6/8.RS V0	beige		0196 987.03
FEMR8T V0	2,8 mm .110"		
M 6/8.STP.RS V0	beige		0196 991.07
FEMR10 V0			
M 10/10.RS V0	beige		0194 434.06
FEM8S V0	1,5 mm .059"		
M 4/6.SF V0	beige		0196 951.16
M 4/6.SN V0			
FEM12 V0	3 mm .118"		
M 16/12 V0	beige		0198 618.02
M 16/12.N V0	blue		0199 303.00
FEM12F V0	3 mm .118"		
M 6/12.FF V0	beige		0114 023.04
FEM13F V0	1 mm .039"		
M 6/13.FF V0	beige		0196 977.17
FEM16 V0	3 mm .118"		
M 35/16 V0	beige		0198 233.20
M 35/16.N V0	blue		0199 304.01
FEM22 V0	3 mm .118"		
M 70/22 V0	beige		0193 065.16
FEMT2 V0	1 mm .039"		
M 6/8.ST V0	beige		0193 629.20
FEMS6 V0	3 mm .118"		
MS 4/6	beige		0193 885.02
FEM8D1 V0	1 mm .039"		
M 6/8.D2	beige		0196 656.26
FEMT5 V0	2,5 mm .098"		
M 10/10.St.Sn	beige		0196 781.14

Specific end sections for A.D.O. terminal blocks

Type	Thickness	Color	P/N
Blocks			
FEDAD1	3 mm .118"		
D 2,5/5...ADO	grey		0199 336.20
D 4/6...ADO	grey		0199 339.03
D 6/8...ADO			
D 6/8...ADO3			
FEDAD4	2 mm .079"		
D 4/6.S...ADO	grey		0199 352.00
D 4/8.S...ADO			
FEDAD5	2 mm .079"		
D 1,5/6.S...ADO	grey		0199 354.02
D 2,5/8.S...ADO			
FEDAD6	1,5 mm .059"		
D 4/8.SF...ADO...	grey		0199 356.04
D 4/8.SNN...ADO...			
FEDAD7	1,5 mm .059"		
D 1,5/8.S...ADO	grey		0199 382.27
D 2,5/8.S...ADO2			
FEMAD3	3 mm .118"		
D 1/5...ADO	grey		0199 341.05
D 1,5/6...ADO	yellow		0199 343.07
D 2,5/8...ADO			
D 4/8...ADO			
FED2AD1	5 mm .196"		
D 4/6.D2.ADO	grey		0199 417.12
D 4/6.D2.ADO.1			
FED2AD2	5 mm .196"		
D 1,5/6.D2.ADO	grey		0199 476.25

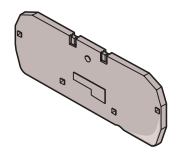
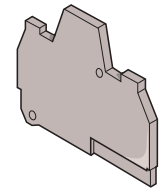

Specific end sections for spring connection terminal blocks

Type	Thickness	Color	P/N
FED1.L V0	1,5 mm .059"		
DR 2,5/5...2L	grey		0291 301.02
DR 2,5/10...4L	orange		0291 302.03
DS 2,5/5...2L			
DS 2,5/10...4L			
FED5.2L V0	2,5 mm .098"		
D 2,5/5...2L	grey		0291 061.24
D 4/6...2L	orange		0291 062.25
FED5.3L V0	2,5 mm .098"		
D 2,5/5...3L	grey		0291 051.22
	orange		0291 052.23
FED5.4L V0	2,5 mm .098"		
D 2,5/5...4L	grey		0291 041.20
D 2,5/5.2L.2L	orange		0291 042.21
FED8.2L V0	2,5 mm .098"		
D 6/8...2L	grey		0291 161.25
	orange		0291 162.26
FED8SF.2L V0	3 mm .118"		
D 2,5/8.S...2L	grey		0291 131.17
	orange		0291 132.10

FE End sections (cont.)

Rail mounted end sections

FEM61

This end section mounts on the rail next to the open side of the block. It does not snap on the block itself.

This end section is aligned with the blocks:



- MA 2,5/5
- M 4/6
- M 6/8
- M 10/10
- M 4/6.NT
- M 6/8.NT
- M 10/10.NT
- M 4/6.SNT

Thickness: 3 mm .12"

FEM61

0114 776.23

FEM6C

This end section mounts on the rail next to the open side of the block and offers the possibility of protecting or identifying the assembly with a cover type CPM and a marker-holder type PEP. An end section is advised every foot for support of the cover.

This end section is aligned with the blocks:



- MA 2,5/5
- M 4/6
- M 6/8
- M 10/10
- M 4/6.NT
- M 6/8.NT
- M 10/10.NT
- M 4/6.SNT

Thickness: 3 mm .12"

FEM6C

0114 777.24

FEH

Two types of end section:

1 For stud terminal blocks of HD type..., and various blocks, a special closing section must be used for one of the two end elements.

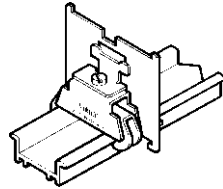

FEH3 th. 1 mm (.040") **0198 352.07**

FEH4 th. 1 mm (.040") **0193 878.22**

FEHD1 th. 1 mm (.040") **0199 400.06**

FEH7 th. 1 mm (.040") **0197 222.14**

FEH8 th. 1,5 mm (.059") **0198 729.01**

FEH9 th. 1,6 mm (.063") **0198 549.05**

2 For the other blocks, a flange must be placed at each end of the terminal block in order to conserve insulation between the blocks and the metal stops.

This flange can hold a CP cover, together with a PEF terminal block identification door. It determines the height of the assembly: 31.8 mm or 40 mm or 50.5 mm (1.25" or 1.57" or 1.99")

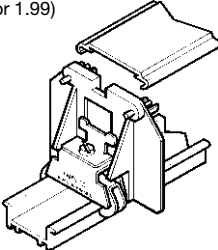

FEH2 th. 3 mm (.118") **0193 472.13**

FEH2 th. 3 mm (.118") **0199 395.24**
yellow

FEH6 th. 3 mm (.118") **0198 059.05**

FEH6 th. 3 mm (.118") **0199 392.21**
yellow

FJ Separator end section

This is used to hold a cover in the middle of the terminal block. Like the FEH, it determines the height of the assembly: 31,8 mm, 40 mm, or 50.5 mm (1.25", 1.57", or 1.99"). Using this makes it unnecessary to use an SC separator, but requires the presence of FEH at the end of the terminal blocks.

Intermediate flange without changing the assembly height.

For assembly height 31.8 mm (1.25")

th. 3,6 mm (.142")

FJH32 **0193 151.11**

FJH32 **0199 406.20**
yellow

For assembly height 40 mm (1.57")

th. 3mm (.118")

FJH40 **0199 401.23**

For assembly height 50 mm (1.97")

th. 3 mm (.118")

FJH50 **0193 495.03**

For assembly height 55 mm (2.16")

th. 1,5 mm (.059")

FJH50 **0193 495.03**

Intermediate flange changing the height 40 mm / 50 mm (1.57" / 1.97").

th. 3 mm (.118")

FJDH **0193 496.04**

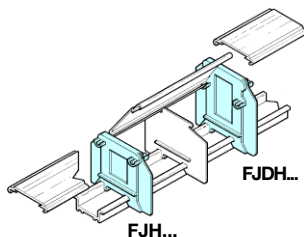

SC Circuit separator and separator end section

The body of standard terminal blocks, series 5 000, is open in the central upper part for the passage of the jumper bar..

In order to maintain clearance between 2 open blocks equipped with test sockets or between two series of open blocks equipped with jumper bars of different potential, the insulator opening must be covered by a circuit separator.

Circuit separator

SCM

An SCM separator snaps onto the top of the open terminal blocks, once the terminal board is assembled.

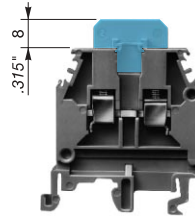

This accessory does not increase the thickness of the block.

For M 2,5/5 blocks

SCM5 grey **0113 001.16**

blue **0123 001.10**

For M 2,5/5 V0 blocks

SCM5 V0 beige **0196 728.26**

For MA 2,5/5 blocks

SCMA5 grey **0116 728.25**

For MA 2,5/5.D blocks

SCMA5D grey **0116 720.21**

For M 1,5/6.HH and ADV blocks, M 4/6, M 6/8, M 10/10, M 16/12 blocks

SCM6 grey **0113 003.10**

blue **0123 003.12**

yellow **0103 020.23**

orange **0103 233.21**

green **0103 234.22**

For M 4/6 V0, M 6/8 V0, M 10/10 V0, M 16/12 V0 blocks

SCM6 V0 beige **0193 003.11**

For M 4/6.D blocks

SCM6D grey **0113 482.05**

For M 4/6.D V0 blocks

SCM6D V0 beige **0193 482.06**

For ADO blocks

SCAD grey **0196 896.00**

SCD

Separator for use with LNTP blocks only. It is snapped onto the extremity of the BJM62 connector bars before they are mounted on the blocks.



SCD white **0103 189.26**

SCH

A separator inserted between two terminal blocks ensures lateral insulation or increases leakage lines between respective conducting parts.

When mounted with the cover, the SC acts as a reinforcement to the cover, since it corresponds to the assembly height.

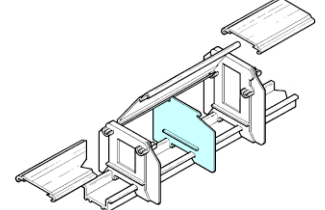

For mounting with HD type block

th. 1,6 mm (.062")

SCH3 **0198 692.25**

th. 4 mm (.157")

SCH6 **0199 393.22**

For assembly height 31.8 mm (1.25")

th. 1 mm (.039")

SCH1 **0193 251.25**

SCH1 **0199 407.21**
yellow

For assembly height 40 mm (1.57")

th. 1,2 mm (.047")

SCH2 **0198 650.16**

SCH2 **0199 389.06**
yellow

For assembly height 50.5 mm (1.99")

th. 1,2 mm (.047")

SCH5 **0198 060.02**

For assembly height 57 mm (2.24")

with HD type block

th. 1,2 mm (.047")

SCH8 **0199 412.15**

SC Circuit separator and separator end section (cont.)

Separator end section

Snap-on end sections for blocks / separators

SCF

An SCF separator is snapped onto the terminal block before mounting on the rail. It can also be used as an end section.

✓ Allows mounting of a protective cover CPM, and a marker-holder PEP.

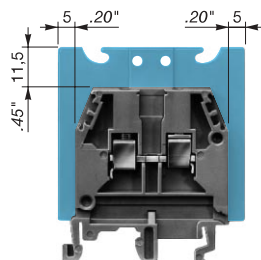

✓ Allows marking, by the user, on the back of the separator.

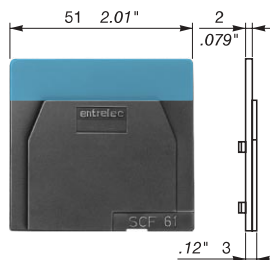

For blocks : **M 4/6** except **D** and **G**
M 6/8 - M 10/10
M 4/6.H
M 1,5/6.HH and **ADV**

Thickness : 2 mm .079"

SCF61 grey **0114 202.25**

✓ For **M 4/6.D** block only

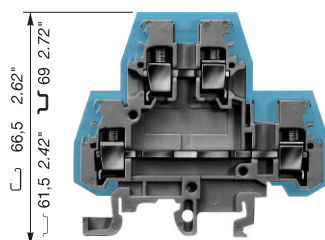

Extends 2 mm .079" around the block.

Thickness : 1 mm .039"

For **M 4/6.D** block

SCF6.D grey **0118 495.17**

For **M 4/6.D V0** block

SCF6.D V0 beige **0198 495.10**

✓ Only for **NTLP** blocks with cut-out for busbar passage. Snapped on **PR3**, **PR4** and **PR5** rails.

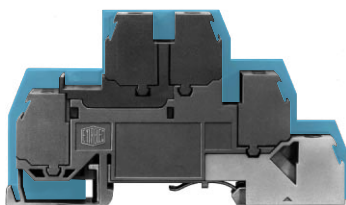

Extends 3 mm .12" around the block except the top.

Thickness : 1,5 mm .059"

SCF.D grey **0114 117.07**

Snap-on end sections for rails / separators

SCFM6

✓ Allows mounting of a protective cover CPM, and a marker-holder PEP. Mounting on **PR1**, **PR3**, **PR4** and **PR5** rails

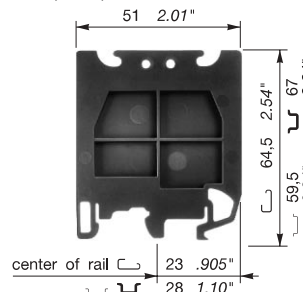

For blocks : **M 4/6**
M 6/8
M 10/10

Thickness : 3 mm .118"

SCFM6 grey **0114 825.05**

SCF9

✓ Allows mounting of a protective cover CPM, and a marker-holder PEP. Mounting on **PR1**, **PR3**, **PR4** and **PR5** rails

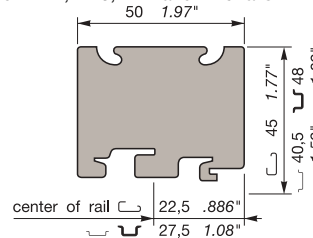

For blocks : **M 6/9.EE**
M 6/12.FF

Thickness : 1 mm .039"

SCF9* white **0103 672.01**

* This separator does not replace an end section which must be used on the block.

SCFT1

✓ Separator for use with 1/4 turn terminal blocks, which allows mounting of one or two protective covers CPM side by side.

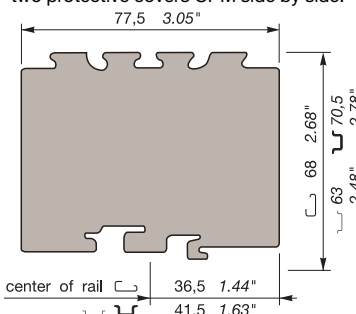

Thickness : 1 mm .039"

SCFT1 grey **0103 588.26**

Same snap-on feature as separator SCF9
Thickness of the separator : 77,5 mm 3.05"

SCFEX

Separator for use with explosive atmosphere terminal blocks.

It can also be used for blocks spacing 5 to 16 mm.

✓ Mounting on **PR3** and **PR5** rails

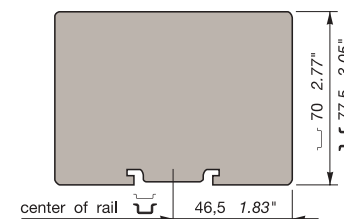

Thickness : 2,4 mm .094"

SCFEX3* grey **0103 620.01**

✓ Mounting on **PR1** rail only.

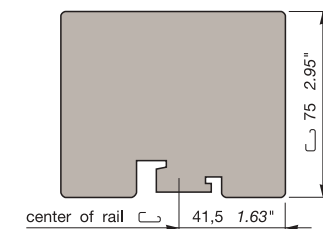

Thickness : 2,4 mm .094"

SCFEX1* grey **0103 619.04**

* When the block used has snap-on feature, use circuit separator SCF.

SC Separator end section

(cont.)

SCFCV

Allows mounting of a protective cover CPM and a marker-holder PEP.

Thickness: 3 mm .12"

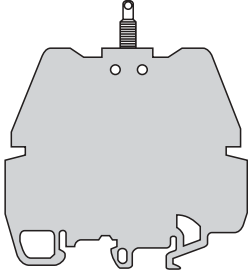

For blocks:

MA 2,5/5 - M 4/6 - M 6/8
M 10/10 - M 16/12 - M 35/16

SCFCV1-2 grey **0116 795.11**

SCFCV1-2 V0 beige **0196 795.12**

For blocks:

M 6/8.STA - M 6/8.SF

SCFCV3 grey **0116 796.12**

SCFCV3 V0 beige **0196 796.13**

For blocks:

M 70/22 - MB 25/30.SF - MB 10/24.SF
M 10/12.SF - MU 10/13
M 10/13.TSF

SCFCV4 grey **0116 797.13**

SCFCV4 V0 beige **0196 797.14**

For blocks:

M 6/8.ST

SCFCV5 grey **0116 798.24**

SCFCV5 V0 beige **0196 798.25**

CP Protective cover

CPV

Protective cover of transparent PVC, length 1 m 3'3" (39") approx.

For cover mounting, place a separator end section SCFCV every 400 mm approx., at terminal assembly extremities.

It can also be used for marking the terminal unit by means of a blank marker strip RTC, which sticks under the cover.

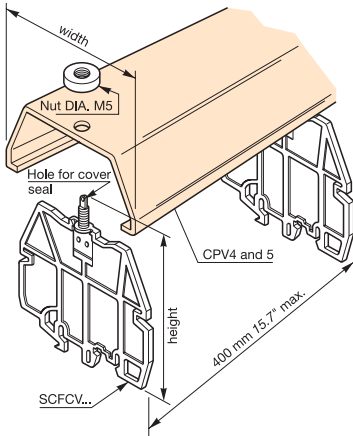

For separator: SCFCV1-2
width: 73 mm 2.87"
length: \sim 66.5 mm 2.62"
 \sim 74 mm 2.91"
 \sim 72 mm 2.83"

CPV1-2 **0176 816.12**

For separator: SCFCV3
width: 85 mm 3.35"
length: \sim 68.5 mm 2.70"
 \sim 76 mm 2.99"
 \sim 74 mm 2.91"

CPV3 **0176 817.13**

For separator: SCFCV4
width: 104 mm 4.09"
length: \sim 90.5 mm 3.56"
 \sim 98 mm 3.86"
 \sim 96 mm 3.78"

CPV4 **0176 791.21**

For separators: SCFCV5
width: 104 mm 4.09"
length: \sim 72 mm 2.83"
 \sim 79.5 mm 3.13"
 \sim 77.5 mm 3.05"

CPV5 **0176 791.21**

CPMS

20 poles divisible cover for 12 poles use.

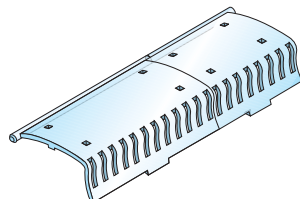

CPMS **0205 227.01**

CPM

Protects the user from accidentally touching live circuits.

This cover is clipped onto the end sections (FE), onto the intermediate sections (FJ), and onto the SCF or SCFM separators. It can also be used for marking the terminal unit by means of a blank strip RTC, which slides into the cover.

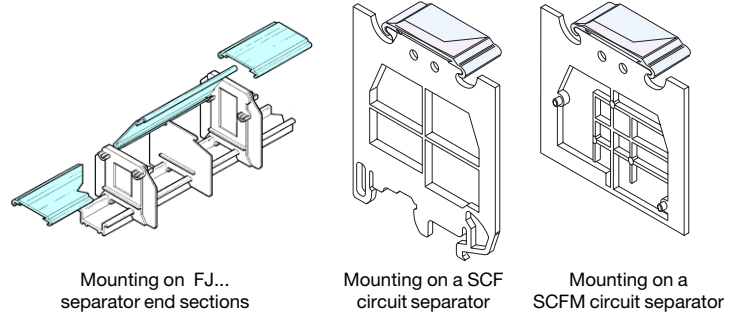

Width 32 mm/1.26", in length of 500 mm/19.70".

CPM	clear	0187 312.14
CPM	beige	0197 312.16
CPM	yellow	0199 405.27

CPP

This type of cover fits only on ECP partitions (for Type I power terminal blocks). It snaps onto the partition and increases the space by 1,5 mm .059".

For each spacing, there are 3 cover sizes, for 1, 2 or 3 blocks.

Thickness of the cover: 1,5 mm.

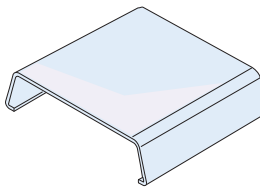

Spacing			
- 26 mm	1 block	CPP261	0168 202.13
	2 blocks	CPP262	0168 201.12
	3 blocks	CPP263	0163 403.20
- 31 mm	1 block	CPP311	0168 204.15
	2 blocks	CPP312	0168 203.14
	3 blocks	CPP313	0163 409.06
- 35 mm	1 block	CPP351	0168 206.17
	2 blocks	CPP352	0168 205.16
	3 blocks	CPP353	0163 418.26
- 42 mm	1 block	CPP421	0168 208.21
	2 blocks	CPP422	0168 207.10
	3 blocks	CPP423	0163 424.14

CPTR Protecting covers for strip terminal blocks

Characteristics - body: Clear PVC
- thickness: 1.5 mm

How to order

1	Mark the type of cover CPTR (table1)
2	Mark the number of contacts on the terminal block

Protecting covers	A
CPTR 38 + CPTR 80	15
CPTR 716	18
CPTR 916	23
CPTR 950	23
CPTR 110	29
CPTR 143	34
CPTR 175	47
CPTR 220	51

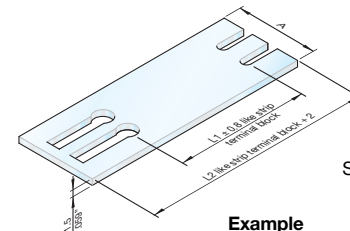

Screw and cross pieces are supplied.

Example

CPTR 716 - 6
Protecting cover for US 716 with 6 poles.

FC Test plug

These accessories, when used with measuring or control equipment, are for trouble shooting or testing of a circuit, on the blocks equipped with a test socket or by use of a test device (for **FC2** only).

FC2

Test plug DIA. 2 mm .079"
(soldered connection : 1 mm² max. - 18 AWG)

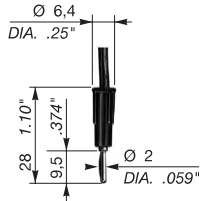

FC2

0007 865.26

FC4

Test plug DIA. 4 mm .16"
(soldered connection : 1,5 mm² max. - 16 AWG)

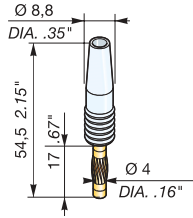

FC4

0167 860.01

AL Test socket

This accessory is screwed into the tapped holes of the connector bar of the terminal blocks. Some blocks are delivered socket mounted. This socket receives an **FC** test plug.



The test sockets are characterized by their internal diameter.

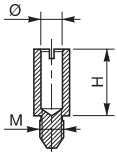

Ø 2 mm H = 12 mm .079" DIA. .472" H

M3 AL2 0163 043.21

Ø 2 mm H = 11.7 mm .079" DIA. .461" H

M2,6 AL2 0163 046.24

Ø 2 mm H = 8.5 mm .079" DIA. .335" H

M3 AL2 0163 070.00

Ø 2 mm H = 9.6 mm .079" DIA. .378" H

M3 AL2 0164 950.00

Ø 2 mm H = 8.5 mm .079" DIA. .335" H

M2,6 AL2 0167 319.06

Ø 3 mm H = 9.5 mm .12" DIA. .374" H

M3 AL3 0163 261.00

Ø 4 mm H = 12 mm .16" DIA. .473" H

M3 AL4 0163 240.17

Ø 4 mm H = 12.3 mm .16" DIA. .484" H

M3 AL4 0163 262.01

Ø 4 mm H = 13.5 mm .16" DIA. .532" H

M4 AL4 0168 237.05

Ø 4 mm H = 17.5 mm .16" DIA. .689" H

M3 AL4 0179 762.16

DC Test device on screw head

This patented device is mounted on the round screwdriver opening. It is used for trouble shooting, measuring and control for monitoring and repairing an installation, on blocks without a test socket. For this, the device receives an **FC2** test plug.

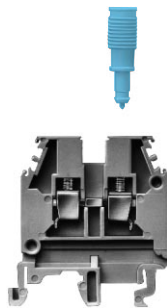

The DCs are differentiated by their color:

green for blocks with 5 mm spacing

DCV 0173 058.02

blue for **MA 2,5/5** blocks

DCB 0105 028.21

yellow for blocks with 6 mm spacing

DCJ 0173 059.03

grey for **M 4/6.D** and **MB 2,5/6** blocks

DCG 0163 218.05

orange for blocks with 8 mm spacing

DCO 0173 060.00

brown for **MB 6/8** blocks

DCM 0163 219.06

Terminal block modular connectors

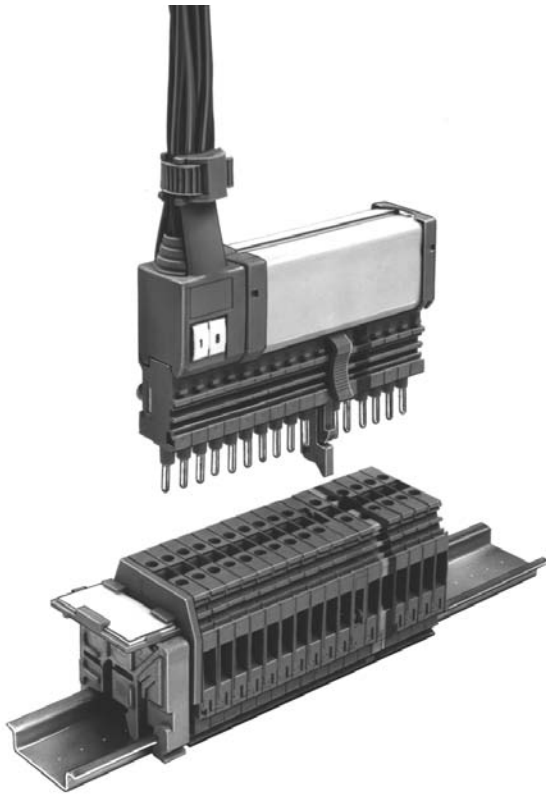

This modular connector is assembled using standard components and is used with standard terminal blocks.

Applications include prewired harnesses to simplify field wiring by eliminating mistakes. Time saving.

The connector can be plugged into the top of the blocks for applications requiring frequent testing or disconnect (this application requires a block equipped with a test socket: see page 1910).

The connector can be screwed into the side of a standard block for applications requiring few disconnects and testing.

Wiring capacity of up to 12 AWG, protective cover and wire holder, marking, and keying make this unit very versatile and efficient.

Factory preassembled connectors are available on request (connection of the plug also on request).

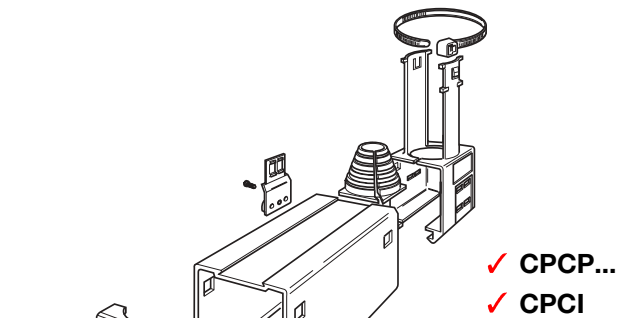

Protective covers - see "Plastic protective cover components"

page 1911

Reversible grey plastic body, cable clamp included.

Plugs - see "Plug components" page 1909

Comprised of connection elements, ground connection elements, and 1 or 2 key elements.

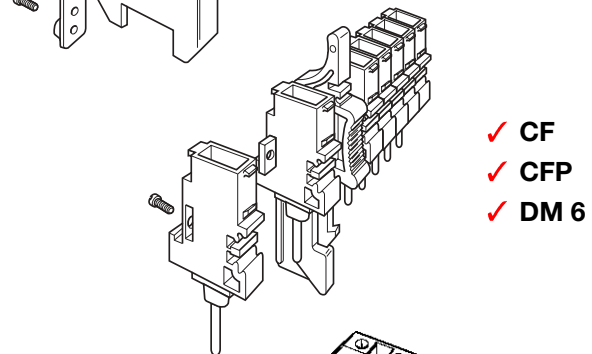

Sockets - see "Socket components" page 1910

Comprised of terminal blocks, ground blocks equipped with a flexible test socket, and 1 or 2 key elements.

These blocks are equipped with a flexible contact for plug insertion in position **2**.

The blocks listed on following page are normally in stock. Other blocks can be equipped, on request, with the flexible contact (consult us).

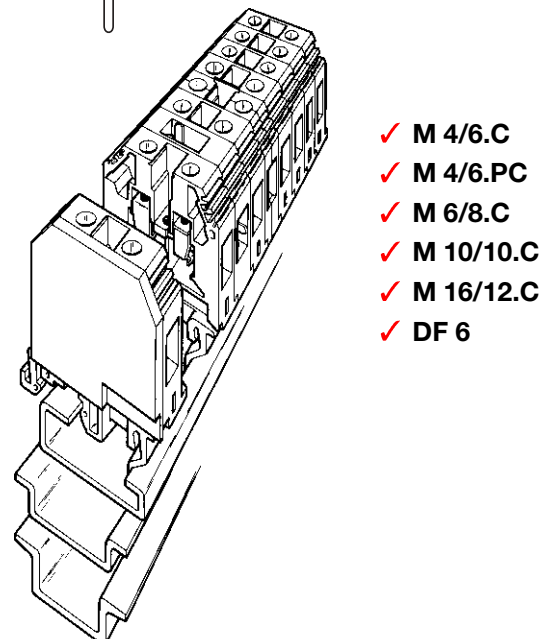

3 mounting possibilities

- It is possible to plug the connectors in position **2** in blocks equipped with a flexible socket for 6, 8, 10 and 12 mm spacing sizes.

- It is possible to plug the connectors in position **1** and **3** directly in the wires' place inside the wire clamps of terminal blocks type **M4/6**, **M6/8**, **M10/10**; the blocks type **M16/12** cannot be mounted this way.

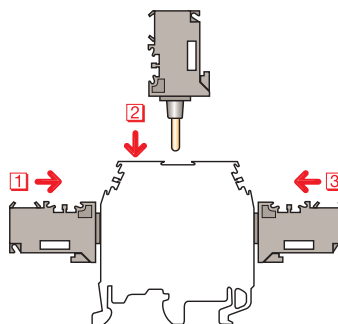

Test connectors



To perform simple tests quickly

This connector completes the range of modular connectors that mount on terminal strips. It is supplied ready for use, without any modification of the terminal strip :
 The contact is made on the wire-clamp screw heads.
 Fastening is performed on the terminal block wire inputs.
 These connectors are supplied connected with 2 meter (6.6 Ft.) long wires. Standard 1 pole and 10 pole models are in stock. On request, 4 to 15 pole models are available.

Unit connector

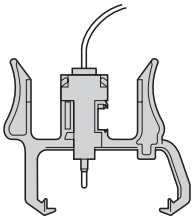

Simple test connector (1 pole) supplied with a 2 meter (6.6 Ft.) long wire.

Multipole connector

4 to 15 pole max. test connector supplied with a 2 meter (6.6 Ft.) long cable. Wires marked from 1 to X.

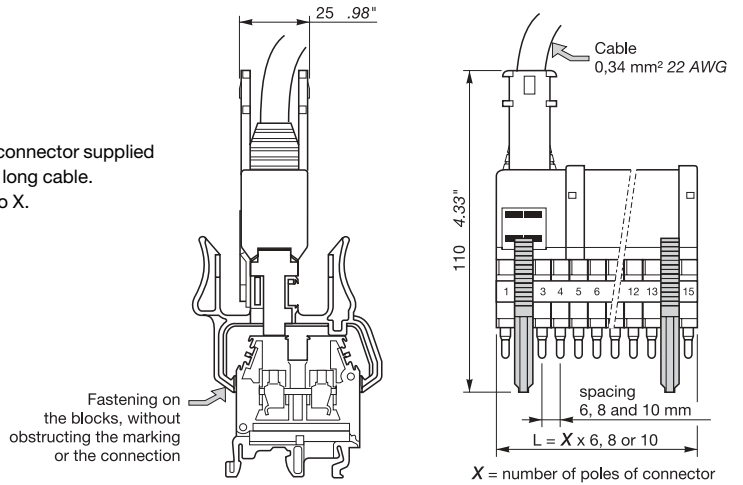

Test connectors on screw head for terminal blocks

Other numbers of poles on request. P/N 0131 003.12 identical for the different poles.
 When ordering, indicate the number of poles required, e.g.:
 spacing 6 mm 4 poles CEV 6.4
 spacing 8 mm 6 poles CEV 8.6
 spacing 10 mm 8 poles CEV 10.8

CEV 6 ...

Spacing 6 mm + 0,05 .238"

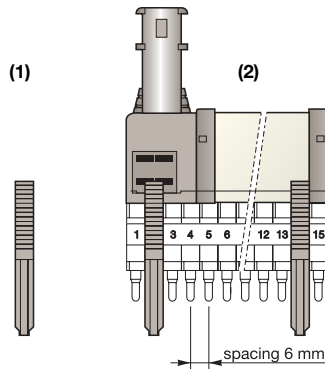

(1) Unit test connector on screw head for M 4/6, M 6/8 and M 10/10 blocks.
 (2) Test connector (X poles) on screw head for M 4/6 blocks.

CEV 8 ...

Spacing 8 mm + 0,05 .315"

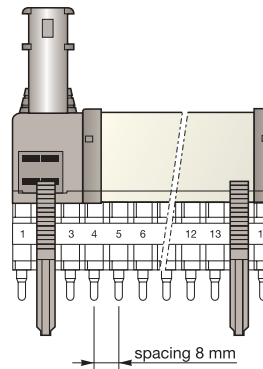

Test connector (X poles) on screw head for M 6/8 blocks.

CEV 10 ...

Spacing 10 mm + 0,05 .394"

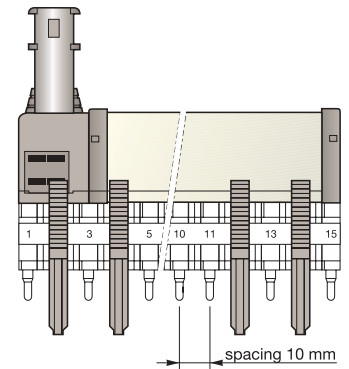

Test connector (X poles) on screw head for M 10/10 blocks.

Type	P/N	Type	P/N	Type	P/N
Grey body (1) Unit connector (1 pole). CEV 6.1	0115 544.14	Grey body 10 pole connector. CEV 8.10	0115 574.12	Grey body 10 pole connector. CEV 10.10	0115 652.20
Grey body (2) 10 pole connector. CEV 6.10	0115 573.11				
CEI 947-7-1 NF.EN 60947 - VDE 0611	UL CSA	CEI 947-7-1 NF.EN 60947 - VDE 0611	UL CSA	CEI 947-7-1 NF.EN 60947 - VDE 0611	UL CSA
Wire size	Screw Solid wire Stranded wire	0,50 mm²(1) 0,34 mm²(2)	0,34 mm²	0,34 mm²	
Rated voltage	V/~	250 *	250 *	250 *	
Rated current	A	2	2	2	

Note : for optimum efficiency, these connectors must not be subjected to shock or vibration.
 * For low voltages (< 24 V), assume a typical contact resistance of 50 mΩ.

Plug components

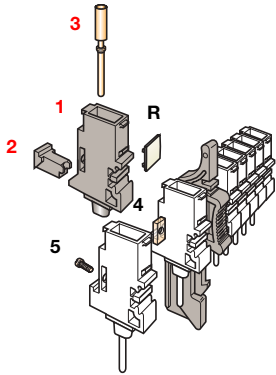

CF

Spacing 6 mm + 0,05 (.238")

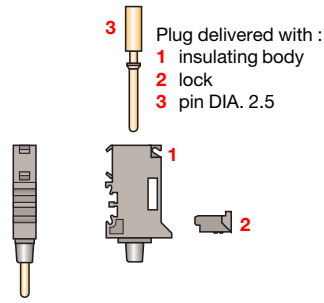

0.22-0.34 mm ²	CF	0115 074.10
0.22-0.5 mm ²	CF	0115 080.13
1.0 mm ²	CF	0115 075.11
1.5 mm ²	CF	0115 076.12
2.5 mm ²	CF	0115 077.13
4.0 mm ²	CF	0115 079.25

CFP

Spacing 6 mm + 0,05 (.238")

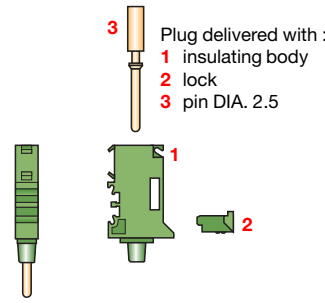

0.22-0.34 mm ²	CFP	0105 007.25
0.22-0.5 mm ²	CFP	0105 018.27
1.0 mm ²	CFP	0105 008.06
1.5 mm ²	CFP	0105 009.07
2.5 mm ²	CFP	0105 010.23
4.0 mm ²	CFP	0105 019.20

DM 6

Spacing 6 mm + 0,05 (.238")

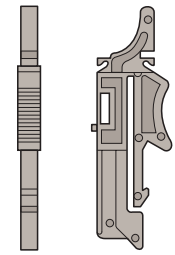

Grey **DM 6** 0114 547.16

Adjustable key element to be mounted on the fixed key element **DF 6**. Slides on the assembly bar close to the plug elements in the required place (+ potential separators). Allows polarization and locking of the connector on the assembly.

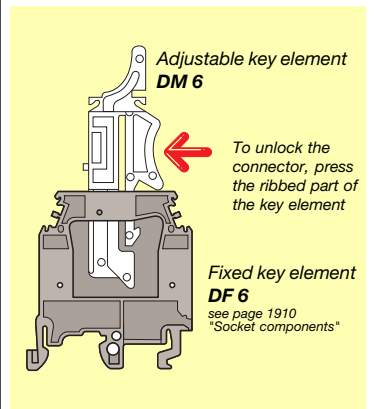

Characteristics

Wire size mm ² / AWG	IEC		UL	CSA	IEC		UL	CSA
	NFC	DIN			NFC	DIN		
KY 30	0.22 - 0.34 mm ²		24 - 22 AWG		0.22 - 0.34 mm ²		24 - 22 AWG	
KY 30 and H05.VK	0.22 - 0.5 mm ²		24 - 20 AWG		0.22 - 0.5 mm ²		24 - 20 AWG	
H05.VK	1.0 mm ²		18 AWG		1.0 mm ²		18 AWG	
H07.VR or VK	1.5 mm ²		16 AWG		1.5 mm ²		16 AWG	
H07.VR or VK	2.5 mm ²		14 AWG		2.5 mm ²		14 AWG	
H07.VR or VK	4.0 mm ²		12 AWG		4.0 mm ²		12 AWG	
Rated voltage	800 V				800 V			
Rated current	15 A				15 A			
Rated wire size	1 mm ²				1 mm ²			
Wire stripping length	10 mm / .39"				10 mm / .39"			

Components

A PLUG ELEMENT CONSISTS OF THE THREE FOLLOWING PARTS, EACH ELEMENT CAN BE ORDERED USING ITS OWN PART NUMBER OR USING ITS COMPONENTS' PART NUMBERS

Part	Material	Color	Part Number
1 Insulating body	SIC	grey	0113 108.26
2 Lock	VRC	grey	0113 110.13
3 Pin DIA. 2,5 mm .10"	BRC	0,22 to 0,5 mm ²	0174 558.05
	BRC	1.0 mm ²	0173 906.22
	BRC	1.5 mm ²	0173 907.23
	BRC	2.5 mm ²	0173 908.04
	BRC	4.0 mm	0174 601.01

Accessories

Part	Material	Color	Part Number
4 Assembly bar	BDA	see table below	
5 Assembly screw	VSA		0164 408.06
6 Separator	IN10	th. 1.0 mm	0113 112.01
	IN16	th. 1.6 mm	0113 114.03
	IN20	th. 2.0 mm	0113 115.04
	IN24	th. 2.4 mm	0113 116.05

Mounting screw to be ordered for mounting without cover. These screws are delivered with the cover sub-assembly.

BDA - Assembly bar

Plug components, separators and adjustable key elements slide on this bar. BDA is defined regarding the required assembly. For this, calculate the length of these accessories in millimeters using the following formulas :

Assembly with 1 key element not mounted at the end of the assembly

$$\text{Spacing } (n-1) + 12$$

Assembly with 2 key elements 1 at each end of the assembly

$$n (\text{Spacing}) + 12$$

n = number of elements included into the plug
L = length of the plug

L mm	A mm	B mm	Bar BDA
24	22	18	0167 054.20
30	28	24	0167 055.21
36	34	30	0167 056.22
42	40	36	0167 057.23
48	46	42	0167 058.04
54	52	48	0167 059.05
60	58	54	0167 060.02
66	64	60	0167 061.27
72	70	66	0167 062.20
78	76	72	0167 063.21
84	82	78	0167 064.22
90	88	84	0167 065.23
96	94	90	0167 066.24
102	100	96	0167 067.25
108	106	102	0167 068.06
114	112	108	0167 069.07
120	118	114	0167 070.04
1000			0008 370.22

Machining diagram for bar processing by customer, supplied in length 1000 mm.

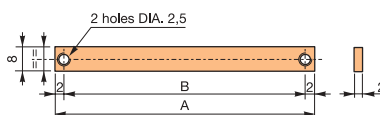

Assembly of a connector

Mounting an element

- Crimp the wire in the pin,
- Insert the pin into the insulator,
- Lock in place by pushing it completely in (snaps in).

Removing the pin

- Unlatch the lock, using a screwdriver,
- Push back the pin.

Re-mounting of the element

(see "Mounting an element").

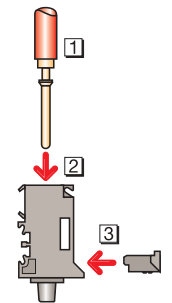

Crimping

Use conductors of 0.22 to 0.34 mm² (24-22 AWG) and AMP crimping tool 46 256 Remove the positioning stops and use only the oval mold.

Conductors of 0.22 to 0.5 - 1 - 1.5 - 2.5 - 4 mm² ENTRELEC crimping tool

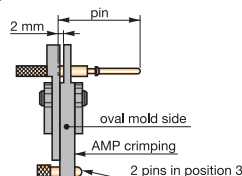

PSC 0173 181.13

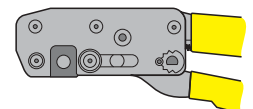

Socket components

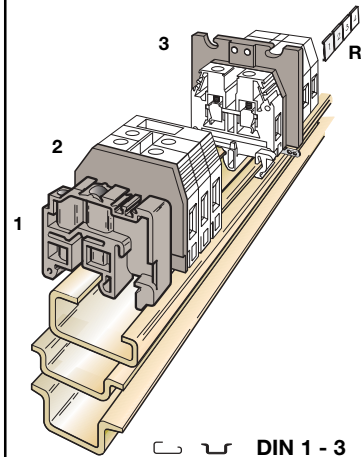

DIN 1 - 3

M 4/6.C

Spacing 6 mm + 0,05 (.238")

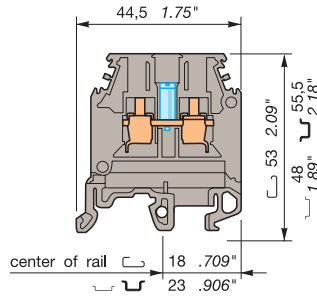

Grey **M 4/6.C 0115 208.04**

6 mm terminal block, equipped with a flexible test socket DIA. 2.5 mm .10" for connector.

M 4/6.PC

Spacing 6 mm + 0,05 (.238")

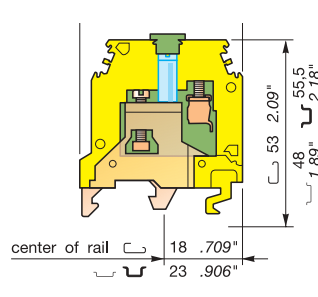

Green/Yellow **M 4/6.PC 0165 294.24**

6 mm ground block, equipped with a flexible test socket DIA. 2.5 mm .10" for connector.

M 6/8.C

Spacing 8 mm - 0,05 (.315")

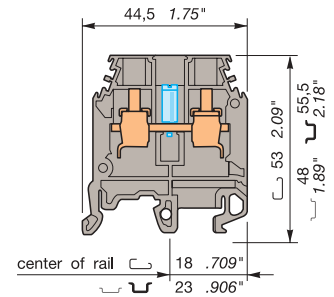

Grey **M 4/8.C 0115 209.05**

8 mm terminal block, equipped with a flexible test socket DIA. 2.5 mm .10" for connector.

If the last block of the assembly is a terminal block, an end section is required.

Characteristics

Wire size mm² / AWG

	IEC			UL			CSA												
	NFC	DIN	DIN				NFC	DIN	DIN										
Solid wire	0,2 - 4 mm ²			22-10 AWG			22-10 AWG			0 - 4 mm ²			0,5 - 10 mm ²			22-8 AWG			24-8 AWG
Stranded wire	0,22 - 4 mm ²			22-10 AWG			22-10 AWG			0 - 4 mm ²			0,5 - 6 mm ²			22-8 AWG			24-8 AWG

Rated voltage	800 V	600 V	600 V				800 V	600 V	600 V
Rated current	32 A	30 A	25 A				41 A	50 A	55 A
Rated wire size	4 mm ²	10 AWG	10 AWG				6 mm ²	8 AWG	8 AWG
Wire strip. length - Recomm. screwdriver	9,5 mm / .37" - DIA. 4 mm / .157"			12 mm / .47" - DIA. 4 mm / .157"			12 mm / .47" - DIA. 4-5 mm / .157"-.197"		
Recommended torque	0,5-0,8 Nm / 4.4-7.1 lb.in.			0,4-0,6 Nm / 3.5-5.3 lb.in.			0,8-1 Nm / 7.1-8.9 lb.in.		

Accessories

1 End stop (all rails)	BAM	th. 9.1 mm	0103 002.26	BAM	th. 9.1 mm	0103 002.26	BAM	th. 9.1 mm	0103 002.26
2 End section grey	FEM6	th. 2.8 mm	0118 368.16	FEM6	th. 2.8 mm	0103 062.21	FEM6	th. 2.8 mm	0118 368.16
2 End section yellow									
3 Separator end section grey	SCF6	th. 3.0 mm	0118 707.03	SCF6	th. 3.0 mm	0118 707.03	SCF6	th. 3.0 mm	0118 707.03
R See section on markers marking method									

Ⓜ Other accessories, see Section 1, pages 34-35

Ⓜ Other accessories, see Section 1, pages 38-39

Socket components

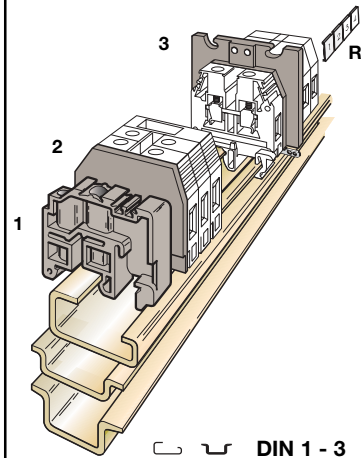

DIN 1 - 3

M 10/10.C

Spacing 10 mm - 0,05 (.394")

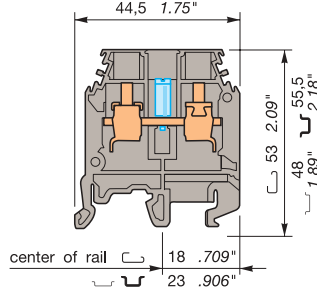

Grey **M 10/10.C 0115 228.27**

10 mm terminal block, equipped with a flexible test socket DIA. 2.5 mm .10" for connector.

M 16/12.C

Spacing 12 mm - 0,1 (.473")

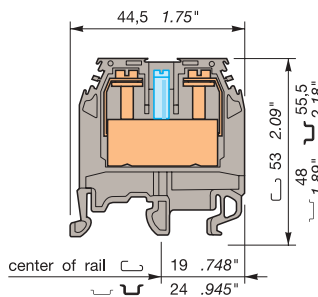

Grey **M 16/12.C 0115 210.21**

12 mm terminal block, equipped with a flexible test socket DIA. 2.5 mm .10" for connector.

DF 6

Spacing 6 mm + 0,05 (.238")

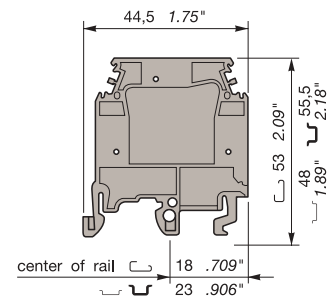

Grey **DF 6 0113 086.03**

Key element snapped onto the rail, placed within the terminal blocks in the required place. 2 slots for markers. Marking method Ⓜ

If the last block of the assembly is a terminal block, an end section is required.

Characteristics

Wire size mm² / AWG

	IEC			UL			CSA												
	NFC	DIN	DIN				NFC	DIN	DIN										
Solid wire	0,5 - 16 mm ²			20-6 AWG			18-6 AWG			2,5 - 25 mm ²			14-4 AWG			14-4 AWG			14-4 AWG
Stranded wire	0,5 - 10 mm ²			20-6 AWG			18-6 AWG			2,5 - 16 mm ²			14-4 AWG			14-4 AWG			14-4 AWG

Rated voltage	800 V	600 V	600 V				800 V	600 V	600 V
Rated current	57 A	65 A	70 A				85 A	85 A	100 A
Rated wire size	10 mm ²	6 AWG	6 AWG				16 mm ²	4 AWG	4 AWG
Wire strip. length - Recomm. screwdriver	12 mm / .47" - DIA. 5,5-6 mm / .217"-.238"			14 mm / .55" - DIA. 5,5 mm / .22"			1,2-1,4 Nm / 10.6-12.3 lb.in.		
Recommended torque	1,2-1,4 Nm / 10.6-12.3 lb.in.			1,2-1,4 Nm / 10.6-12.3 lb.in.			1,2-1,4 Nm / 10.6-12.3 lb.in.		

Accessories

1 End stop (all rails)	BAM	th. 9,1 mm	0103 002.26	BAM	th. 9,1 mm	0103 002.26	BAM	th. 9,1 mm	0103 002.26
2 End section grey	FEM6	th. 2,8 mm	0118 368.16	FEM12	th. 3 mm	0118 618.01	FEM12	th. 3 mm	0118 618.01
2 End section yellow									
3 Separator end section grey	SCF6	th. 3,0 mm	0118 707.03	SCF12	th. 3,0 mm	0113 102.10	SCF12	th. 3,0 mm	0113 102.10
R See section on markers marking method									

Ⓜ Other accessories, see Section 1, pages 40-41

Ⓜ Other accessories, see Section 1, pages 42-43

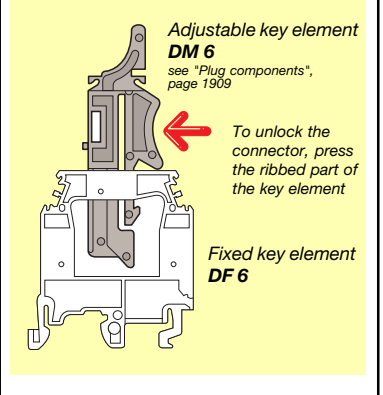

Plastic protective cover components

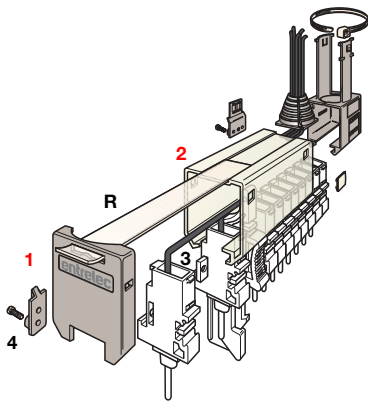

Min. mounting 24 mm .945"

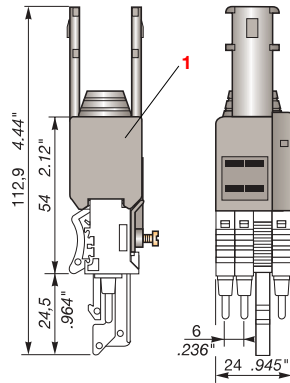

Grey **CPCP4** 0114 432.03
1 Cover sub-assembly

Mounting up to 30 mm 1.18"

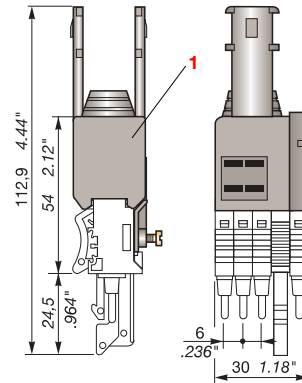

Grey **CPCP5** 0114 431.02
1 Cover sub-assembly

Mounting beyond 30 mm 1.18"

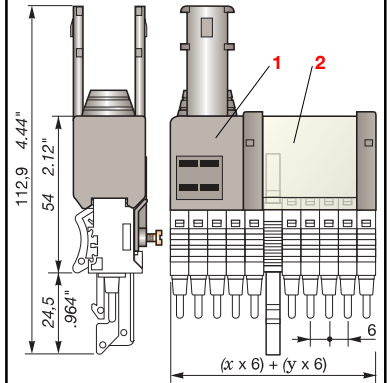

Grey **CPCP6** 0114 430.15
1 Cover sub-assembly

Grey **CPCI**
2 Cover - see table, in left column

Accessories

- 3 Mounting bar
- 4 Assembly screw

BDA to be ordered with the plug
VSA 2 screws delivered with the cover sub-assembly

BDA to be ordered with the plug
VSA 2 screws delivered with the cover sub-assembly

BDA to be ordered with the plug
VSA 2 screws delivered with the cover sub-assembly

R See section on marking; Marking method

⑥

⑥

⑥ ⑬

Part numbers of covers and mounting bars

BDA and **CPCI** must be defined in accordance with the required assembly. For this, calculate the length of these accessories in millimeters using the following formulas :

Assembly with 1 key element - not mounted at the end of the assembly

(see "Assembly", page 1912)

$$\text{Spacing (n-1) + 12}$$

Assembly with 2 key elements - 1 at each end of the assembly

(see "Assembly", page 1912)

$$n (\text{Spacing}) + 12$$

(n = number of plugs in the connector)

Length mm	Bar BDA	Cover 2 CPCI	Cover sub-assembly 1 CPCP...
24	0167 054.20	-	0114 432.03
30	0167 055.21	-	0114 431.02
36	0167 056.22	0114 353.23	0114 430.15
42	0167 057.23	0114 354.24	0114 430.15
48	0167 058.04	0114 356.26	0114 430.15
54	0167 059.05	0114 358.00	0114 430.15
60	0167 060.02	0114 359.01	0114 430.15
66	0167 061.27	0114 361.23	0114 430.15
72	0167 062.20	0114 375.21	0114 430.15
78	0167 063.21	0114 377.23	0114 430.15
84	0167 064.22	0114 380.23	0114 430.15
90	0167 065.23	0114 381.10	0114 430.15
96	0167 066.24	0114 383.12	0114 430.15
102	0167 067.25	0114 385.14	0114 430.15
108	0167 068.06	0114 390.25	0114 430.15
114	0167 069.07	0114 401.15	0114 430.15
120	0167 070.04	0114 404.10	0114 430.15
1000	0008 370.22	0114 427.06	0114 430.15

Machining diagram for cutting of covers by the user; sold in lengths of 1000 mm.

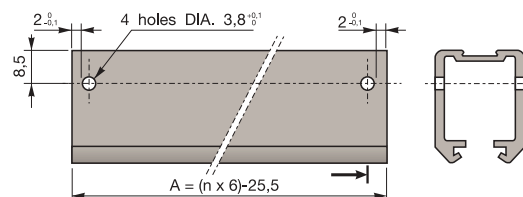

Assembly of the cover on a connector unit up to 30 mm.

(the connector unit already preassembled on its mounting bar ①)

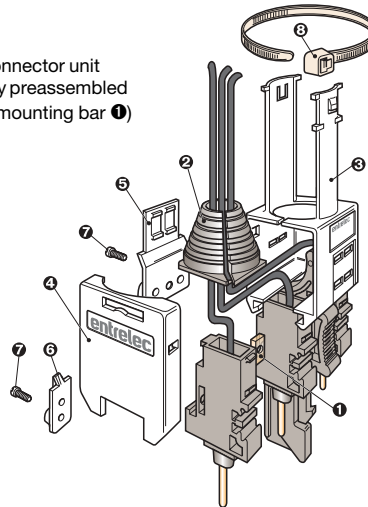

Assembly procedure

1. Cut the wire-guide ② if necessary, to the required diameter and close it around the wire.
2. Place the wire-guide in the cover ③ taking care to orient it correctly (ENTRELEC marking visible).
3. Slide the cover ③ over the elements.
4. Snap the cap ④ on the cover ③.
5. Snap part ⑤ on the cover ③ and tighten the assembly by the screw ⑦ facing the end piece.
6. Lock the cap ④ using part ⑥ and tighten the assembly by a screw ⑦.
7. Clamp the wire between the cable-clamp tags, using a wire tie ⑧, 4,6 mm to 9 mm wide.

Note : The cable clamp cover ⑥ and the cap ④ can be mounted either to the right or to the left of the connector unit.

Assembly of the cover on a connector unit longer than 30 mm.

(the connector unit already preassembled on its mounting bar ①)

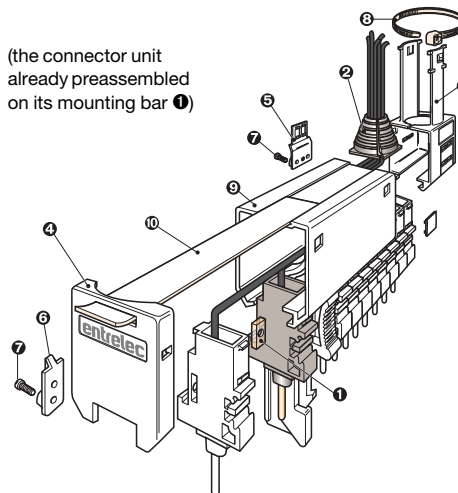

Assembly procedure

1. Cut the wire-guide ② if necessary, to the required diameter and close it around the wire.
2. Place the wire-guide in the cover ③ taking care to orient it correctly (ENTRELEC marking visible).
3. Slide the cover ③ over the elements.
4. Slide the hood ⑨ over the elements until it latches on the cover ③.
5. Snap the cap ④ onto the hood ⑨.
6. Snap part ⑤ on the cover ③ and tighten the assembly by a screw ⑦ facing the end piece.
7. Lock the cap ④ using part ⑥ and tighten the assembly by a screw ⑦.
8. Clamp the wire between the cable-clamp tags, using a polyamid wire tie ⑧, 4,6 mm to 9 mm wide.
9. Mark the hood ⑨ if required, using the blank strip ⑩ for manual inscriptions.

Assembly

The spacing of the connector assembly is determined by the thickness of the plug elements : 6 mm. This spacing increases using separators **IN** to be located between the elements up to 8, 10, or 12 mm spacings.
 To get these spacings, see examples below by function of the number of key elements: 1 or 2 (n is the number of elements in the connector).

Example :

Separator	Number
IN10	= 2
IN20	= n-2

IN - Grey separator

IN10	0113 112.01	th.	1,0 mm
IN16	0113 114.03	th.	1,6 mm
IN20	0113 115.04	th.	2,0 mm
IN24	0113 116.05	th.	2,4 mm

Assembly spacing 6 mm

with 1 key element DM 6
 NOT MOUNTED AT THE END OF THE ASSEMBLY

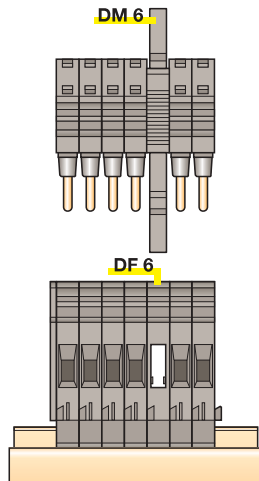

with 2 key elements DM 6
 1 AT EACH END OF THE ASSEMBLY

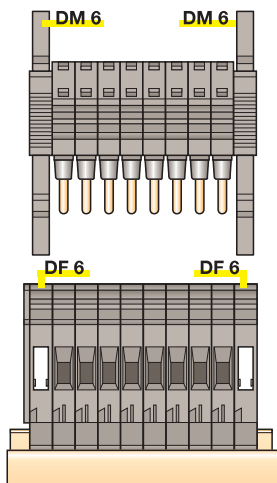

Assembly spacing 8 mm

with 1 key element DM 6
 NOT MOUNTED AT THE END OF THE ASSEMBLY

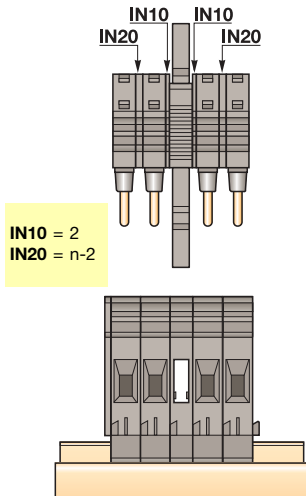

IN10 = 2
 IN20 = n-2

with 2 key elements DM 6
 1 AT EACH END OF THE ASSEMBLY

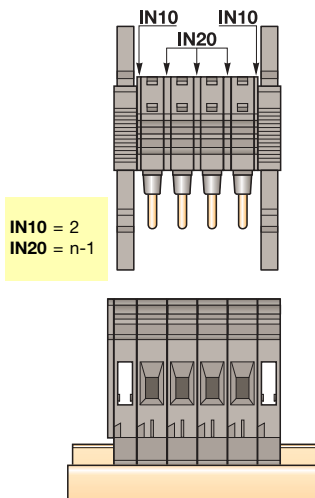

IN10 = 2
 IN20 = n-1

Assembly spacing 10 mm

with 1 key element DM 6
 NOT MOUNTED AT THE END OF THE ASSEMBLY

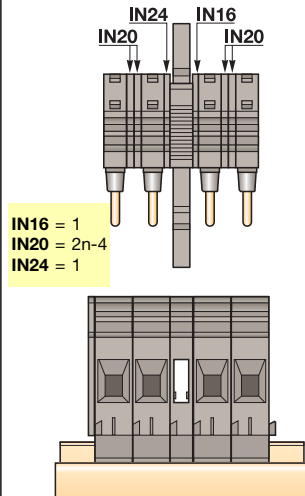

IN16 = 1
 IN20 = 2n-4
 IN24 = 1

with 2 key elements DM 6
 1 AT EACH END OF THE ASSEMBLY

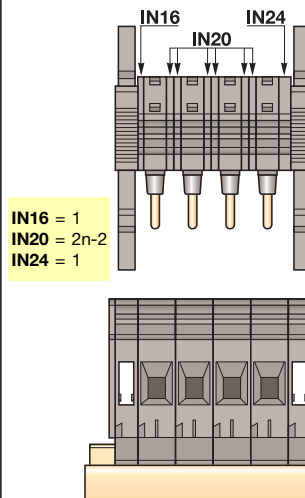

IN16 = 1
 IN20 = 2n-2
 IN24 = 1

Assembly spacing 12 mm

with 1 key element DM 6
 NOT MOUNTED AT THE END OF THE ASSEMBLY

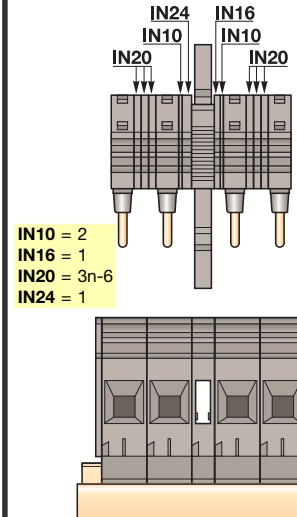

IN10 = 2
 IN16 = 1
 IN20 = 3n-6
 IN24 = 1

with 2 key elements DM 6
 1 AT EACH END OF THE ASSEMBLY

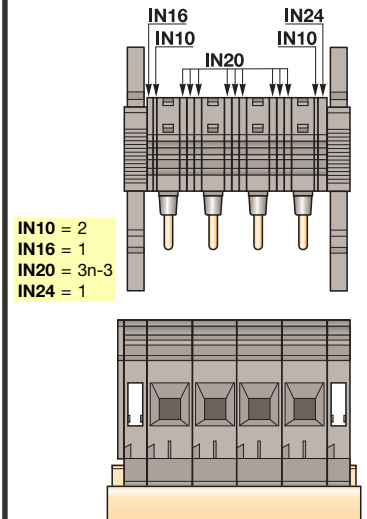

IN10 = 2
 IN16 = 1
 IN20 = 3n-3
 IN24 = 1

IMPORTANT NOTE

When two or several connectors are located side by side, it is necessary to separate, with an end section, the groups of terminal blocks linked with each socket of connectors, so that nothing interferes with removal of one of the connectors.

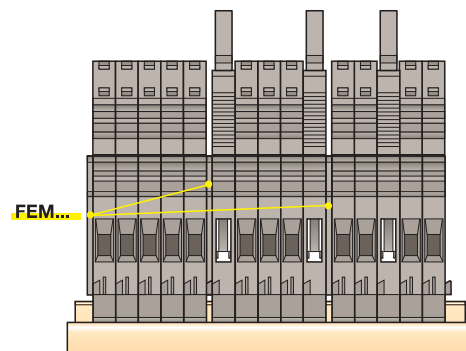

BJ Jumper bar

Use the BJ jumper bar to connect consecutive and nonconsecutive terminal blocks with the same spacing. Two types of jumper bars are available : an assembled unit and a nonassembled unit. Both jumper bars include a metal tube which makes contact with the terminal block's internal connector bar.

To mount the BJ jumper bar accessory onto terminal blocks still having top center partitions, the user must cut out all partitions between the blocks.

When the BJ jumper bar is used with each of two series of connected blocks, the top center opening at the junction of the two series must be closed by a circuit separator or a separator end section SCM, SCF or SCD to permit different voltage potentials on each series jumper bar accessory.



BJM Assembled jumper bar

Two versions of this accessory are available.

Fractionable model, composed of captive screws on a jumper bar system. This accessory can be used for connecting consecutive blocks only.

Simplified model, composed of a bar prepunched to the spacing of the blocks, and of captive screws and spacers. This accessory can be used for connecting blocks, which are consecutive or not : in this case remove the screw and spacer which are not required.

without IP20 protection (standard)



Current capacity, Amps

BJM5	for MA 2,5/5 blocks	
24 A	2 poles	0176 273.01
24 A	3 poles	0176 274.02
24 A	4 poles	0176 275.03
24 A	5 poles	0176 276.04
24 A	10 poles	0176 277.05
BJM6	for M 4/6 blocks	
32 A	2 poles	0168 516.25
32 A	3 poles	0168 517.26
32 A	4 poles	0168 518.07
32 A	5 poles	0168 519.00
32 A	10 poles	0168 973.07
BJM8	for M 6/8 blocks	
41 A	2 poles	0168 520.05
41 A	3 poles	0168 521.22
41 A	4 poles	0168 522.23
41 A	5 poles	0168 523.24
41 A	10 poles	0168 974.00

Max. recommended torque : 0.6 Nm

with IP20 protection (touchproof)



Current capacity, Amps

BJMI5	for MA 2,5/5 blocks	
24 A	2 poles	0176 278.16
24 A	3 poles	0176 279.17
24 A	4 poles	0176 280.05
24 A	5 poles	0176 281.22
24 A	10 poles	0176 282.23
BJMI6	for M 4/6 blocks	
32 A	2 poles	0176 663.00
32 A	3 poles	0176 664.01
32 A	4 poles	0176 665.02
32 A	5 poles	0176 666.03
32 A	10 poles	0176 667.04
BJMI8	for M 6/8 blocks	
41 A	2 poles	0176 669.16
41 A	3 poles	0176 670.13
41 A	4 poles	0176 671.00
41 A	5 poles	0176 672.01
41 A	10 poles	0176 673.02

Max. recommended torque : 0.6 Nm

without IP20 protection (standard)



Current capacity, Amps

BJM5D	for MA 2,5/5.D blocks	
24 A	2 poles	0176 226.22
24 A	3 poles	0176 227.23
24 A	4 poles	0176 228.04
24 A	5 poles	0176 229.05
24 A	10 poles	0176 230.02
BJM6D	for M 4/6.D blocks	
32 A	2 poles	0173 515.11
32 A	3 poles	0173 516.12
32 A	4 poles	0173 517.13
32 A	5 poles	0173 519.25
32 A	10 poles	0173 520.22
BJM62	for D 4/6.LNTP, DR 4/6 blocks	
32 A	2 poles	0173 217.26
32 A	3 poles	0173 218.07
32 A	4 poles	0173 219.00
32 A	5 poles	0173 221.22
32 A	6 poles	0174 112.16
32 A	7 poles	0174 113.17
32 A	8 poles	0174 114.10
32 A	9 poles	0174 115.11
32 A	10 poles	0173 226.27
BJM65	for M 4/6,5.3G blocks	
32 A	2 poles	0174 764.03
32 A	3 poles	0174 765.04
32 A	4 poles	0174 766.05
32 A	5 poles	0174 767.06
32 A	10 poles	0174 768.17
32 A	25 poles	0174 769.10
BJM10	for M 10/10 blocks	
57 A	2 poles	0173 611.21
57 A	3 poles	0173 612.22
57 A	4 poles	0173 613.23
57 A	5 poles	0173 614.24
57 A	10 poles	0173 615.25
BJM12	for M 16/12 blocks	
76 A	2 poles	0179 618.16
76 A	3 poles	0179 619.17
76 A	4 poles	0179 620.14
76 A	5 poles	0179 621.01
76 A	10 poles	0179 622.02
BJM16	for M 35/16 blocks	
110 A	2 poles	0179 613.01
110 A	3 poles	0179 614.02
110 A	4 poles	0179 615.03
110 A	5 poles	0179 616.04
110 A	10 poles	0179 617.05
BJM4	for DR 1,5/4 blocks	
17,5 A	2 poles	0205 735.06
17,5 A	3 poles	0205 736.07
17,5 A	5 poles	0205 737.00
17,5 A	10 poles	0205 738.11

Max. recommended torque : 0.6 Nm
except for **BJM16 (1.2 Nm)**

with IP20 protection (touchproof)



Current capacity, Amps

BJMI5D	for MA 2,5/5.D blocks	
24 A	2 poles	0176 736.21
24 A	3 poles	0176 737.22
24 A	4 poles	0176 738.03
24 A	5 poles	0176 739.04
24 A	10 poles	0176 740.11
BJMI6D	for M 4/6.D blocks	
32 A	2 poles	0179 668.20
32 A	3 poles	0179 669.21
32 A	4 poles	0179 670.26
32 A	5 poles	0179 671.13
32 A	10 poles	0179 672.14

BJMI10	for M 10/10 blocks	
57 A	2 poles	0176 675.04
57 A	3 poles	0176 676.05
57 A	4 poles	0176 677.06
57 A	5 poles	0176 678.17
57 A	10 poles	0176 679.10
BJMI12	for M 16/12 blocks	
76 A	2 poles	0179 626.06
76 A	3 poles	0179 628.10
76 A	4 poles	0179 629.11
76 A	5 poles	0179 630.16
76 A	10 poles	0179 631.03

BJD6	for D 2,5/6.D blocks, triple deck	
24 A	2 poles	0178 024.25
24 A	3 poles	0178 025.26
24 A	4 poles	0178 026.27
24 A	5 poles	0178 027.20
24 A	10 poles	0178 032.25
24 A	20 poles	0178 033.26

Current capacity, Amps

BJD6	for D 2,5/6.D blocks, triple deck	
24 A	2 poles	0178 024.25
24 A	3 poles	0178 025.26
24 A	4 poles	0178 026.27
24 A	5 poles	0178 027.20
24 A	10 poles	0178 032.25
24 A	20 poles	0178 033.26

Max. recommended torque : 0.6 Nm

Max. recommended torque : 0.6 Nm

BJ Jumper bar (cont.)

To connect terminal blocks, place the metal tube into the top center hole on each terminal block to be connected. The metal tube contacts the terminal block's internal connector bar. The perforated bar is cut to length and placed flat along the center opening of the series of terminal blocks. The screw is inserted into the perforated bar's hole which is located directly above the blocks being connected. The screw goes through the threaded metal tube and is screwed into the terminal block's internal connector bar. This completes the electrical connection to the perforated bar and connects the block.

BJS Jumper bar not assembled



Perforated jumper bar to be cut to length

Type of block	Type	P/N	Type	No. of poles	Current car. cap.	P/N
MA 2,5/5 DR 1,5/5	EV5	0168 629.16	BJS5	20	24 A	0177 652.06
MA 2,5/5.D	EV5D	0176 260.10	BJS5D	20	24 A	0177 651.05
M 4/6	EV6	0168 604.16	BJS6	2	32 A	0164 573.22
			BJS6	3	32 A	0164 574.23
			BJS6	4	32 A	0164 575.24
			BJS6	5	32 A	0164 736.25
			BJS6	10	32 A	0164 576.25
			BJS6	20	32 A	0174 784.20
M 4/6.D MD 2,5/6...	EV6D	0168 400.16	BJS61	2	32 A	0168 481.23
			BJS61	3	32 A	0168 482.24
			BJS61	4	32 A	0168 483.25
			BJS61	5	32 A	0168 484.26
			BJS61	10	32 A	0168 485.27
DR 4/6	EVDR6	0168 399.10	BJS62D	10	24 A	0167 601.02
M 6/8	EV6	0168 604.16	BJS8	2	41 A	0164 581.13
M 6/8.ST	EV8S	0168 401.03	BJS8	3	41 A	0164 582.14
M 4/8.D2.SF...J	VJS11	0163 394.26	BJS8	4	41 A	0164 583.15
			BJS8	5	41 A	0164 737.26
			BJS8	15	41 A	0174 788.04
			BJS8	20	41 A	0174 789.05
M 6/9.EE			BJS9,5	2	41 A	0173 815.16
			BJS9,5	3	41 A	0173 816.17
			BJS9,5	4	41 A	0173 817.10
			BJS9,5	5	41 A	0173 818.21
			BJS9,5	10	41 A	0173 819.22
M 10/10	EV6	0168 604.16	BJS10	2	57 A	0164 585.17
			BJS10	3	57 A	0164 586.10
			BJS10	4	57 A	0164 587.11
			BJS10	5	57 A	0168 273.11
			BJS10	10	57 A	0164 588.22
			BJS10	20	57 A	0177 654.00
M 16/12	EV12	0168 664.11	BJS12	2	57 A	0164 589.23
			BJS12	3	57 A	0164 590.20
MB 10/12.SF	screw	0163 574.22	BJS12	4	57 A	0164 591.15
			BJS12	10	57 A	0164 592.16
			BJS12	20	57 A	0177 653.07
M 6/12.FF			BJS12,5	2	41 A	0174 393.20
			BJS12,5	3	41 A	0174 394.21
			BJS12,5	5	41 A	0174 395.22
			BJS12,5	10	41 A	0174 396.23
M 6/13.FF			BJS13	10	125 A	0167 224.27
ML 10/13.SF	screw	0163 394.26	BJS131	2	57 A	0179 846.03
			BJS131	10	57 A	0175 991.11
M 35/16	EV16	0179 627.07	BJS16	2	125 A	0168 241.11
			BJS16	10	125 A	0168 238.16
M 70/22	screw	0173 320.01	BJS22	2	192 A	0173 316.21
			BJS22	3	192 A	0173 317.22
			BJS22	5	192 A	0173 318.03
			BJS22	10	192 A	0173 319.04
MB 10/24.SF	screw	0163 607.04	BJS24	10	30 A	0167 856.21
M 95/26	VJS51	0173 320.01	BJS261	2	232 A	0177 508.07
			BJS261	3	232 A	0177 509.00
			BJS261	5	232 A	0177 510.24
			BJS261	10	232 A	0177 511.11

Max. recommended torque: 0.6 Nm

BJDP Universal jumper bar

This accessory permits the interconnection of two consecutive blocks with different spacings. It is composed of :

- 2 posts
- 2 screws
- 1 connector plate



Kit n°	Current carrying capacity, Amps	P/N
Kit n° I	BJDP1 50	0179 623.03
Kit n° II	BJDP2 95	0179 624.04
Kit n° III	BJDP3 70	0179 625.05
Kit n° IV	BJDP4 50	0174 781.25
Kit n° V	BJDP5 50	0174 782.26

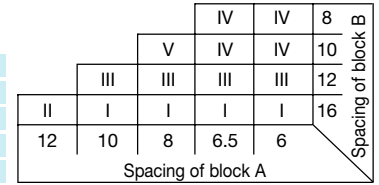

- Note :**
- spacing of block 6 corresponds to **M 4/6** and its derivatives.
 - spacing of block 6,5 corresponds to **M 4/6,5** and its derivatives.
 - spacing of block 8 corresponds to **M 6/8** and its derivatives.
 - spacing of block 10 corresponds to **M 10/10** and its derivatives.
 - spacing of block 12 corresponds to **M 16/12** and its derivatives.
 - spacing of block 16 corresponds to **M 35/16** and its derivatives.

Max. recommended torque : 0.6 mNm

BJDPL Jumper bar for spring blocks with different spacings

This accessory allows the connection of 2 spring terminal blocks with different spacings (spacing 5 and 6 mm, 6 and 8 mm, 5 and 8 mm). When using a jumper bar, it is necessary to use an end section between the interconnected blocks, whatever the mounting direction of the blocks may be.

- BJDPL 56** 0291 150.06 to connect a block of 5 mm and a block of 6 mm spacing
- BJDPL 58** 0291 160.00 to connect a block of 5 mm and a block of 8 mm spacing
- BJDPL 68** 0291 170.02 to connect a block of 6 mm and a block of 8 mm spacing

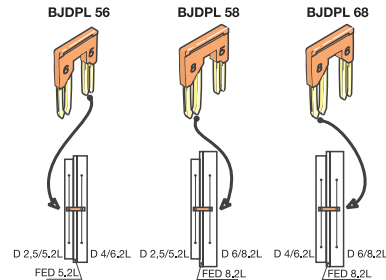

BJDL Jumper bar for spring blocks with same spacing

For blocks spacing 5 mm .200"

- BJDL5.2** 2 poles 0291 102.23
- BJDL5.3** 3 poles 0291 103.24
- BJDL5.4** 4 poles 0291 104.25
- BJDL5.5** 5 poles 0291 105.26
- BJDL5.6** 6 poles 0291 106.27
- BJDL5.7** 7 poles 0291 107.20
- BJDL5.8** 8 poles 0291 108.01
- BJDL5.9** 9 poles 0291 109.02
- BJDL5.10** 10 poles 0291 110.26

For blocks spacing 8 mm .315"

- BJDL8.2** 2 poles 0291 122.16
- BJDL8.3** 3 poles 0291 123.17
- BJDL8.4** 4 poles 0291 144.24
- BJDL8.5** 5 poles 0291 145.25

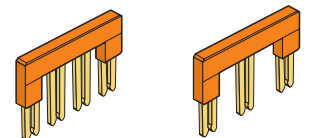

For blocks spacing 6 mm .238"

- BJDL6.2** 2 poles 0291 128.24
- BJDL6.3** 3 poles 0291 129.25
- BJDL6.4** 4 poles 0291 194.17
- BJDL6.5** 5 poles 0291 195.10

For blocks spacing 10 mm .400"

- BJDL10.2** 2 poles 0291 322.26
- BJDL10.3** 3 poles 0291 323.27
- BJDL10.4** 4 poles 0291 324.20
- BJDL10.5** 5 poles 0291 325.21

BJ Jumper bar (cont.)

BJP Pivoting jumper bar



This accessory is for connecting or disconnecting two consecutive blocks, open or closed. The use of a third non-connected block is recommended to allow for a "rest" position of the rotating jumper link. We recommend the use of a circuit separator **SC** in order to preserve the insulation. The **BJP** is mounted in the center of the terminal blocks, the connector bars of which are tapped for receiving the interconnection accessories.



Current capacity

- For blocks with 6 mm .238" spacing
BJP6 35 A **0174 413.14**
 - For double deck blocks with 6 mm .238" spacing
BJP61 35 A **0167 225.20**
 - For blocks with 8 mm .315" spacing
BJP8 50 A **0174 448.07**
 - For blocks with 10 mm .394" spacing
BJP10 70 A **0174 451.22**
 - For double deck blocks with 8 mm .315" spacing
BJP82 50 A **0163 169.04**
 - For blocks DR 4/6 with 6 mm .238" spacing
BJPD6 35 A **0173 223.24**
- Max. recommended torque : 0.6 Nm

BJA Jumper bar for alternated jumping

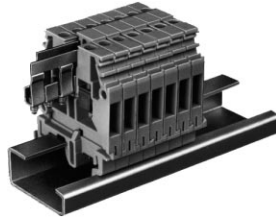

This accessory permits the interconnection of consecutive or nonconsecutive blocks. For this, detach the studs manually where connection is not required. The use of two bars permits alternated jumping. A captive screw is mounted on each stud. This jumper bar is delivered with a protective cover snapped onto the top of the block, assuring touch proof protection.

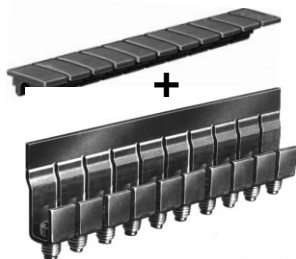

Jumper bar assembly (protective cover included) :

- For blocks with 5 mm .200" spacing
BJA5 24 A 10 poles **0205 021.26**
- For blocks with 6 mm .238" spacing
BJA6 35 A 10 poles **0116 541.12**
BJA6 35 A 30 poles **0116 589.13**

Protective cover, 10 poles :

- For **BJA5** grey **0119 847.20**
- For **BJA6** grey **0116 508.22**
white **0103 819.25**

Note : At each extremity of the jumpers, the assembly must be insulated. For this, use either a closed block or a circuit separator **SC**.

BJADO Screwless jumper bar for mini ADO and ADO blocks spacing 5 or 6 mm only

This accessory permits the interconnection of consecutive or nonconsecutive blocks. For this, detach the studs manually where connection is not required. Due to this flexible connection system, the contact is made by a simple insertion into the ADO jaw. 2 wire connection is permitted. Protection : NEMA 1
Marking with RCT 610 and RCT 810 markers (marking mode 21).

* Important : It is necessary to remove the jumper bar to access the wiring.

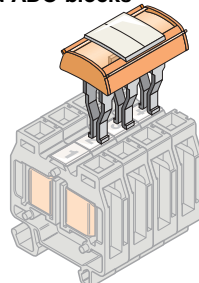

- For ADO blocks spacing 5 mm .200"
BJADO5.2 2 poles **0205 955.03**
BJADO5.3 3 poles **0205 956.04**
BJADO5.4 4 poles **0205 957.05**
BJADO5.5 5 poles **0205 958.16**
BJADO5.10 10 poles **0205 963.03**
BJADO5.20 20 poles **0205 973.05**
 - For ADO blocks spacing 6 mm .238"
BJADO6.2 2 poles **0205 974.06**
BJADO6.3 3 poles **0205 975.07**
BJADO6.4 4 poles **0205 976.00**
BJADO6.5 5 poles **0205 977.01**
BJADO6.10 10 poles **0205 982.27**
BJADO6.20 20 poles **0205 992.21**
- Current capacity : 13,5 A Current capacity : 17,5 A

BJE Jumper bar without screw

✓ for compression clamp and ADO blocks

This accessory permits the interconnection of consecutive or nonconsecutive blocks. For this, detach the studs manually where connection is not required. Due to its flexible connection system, the contact is made by a simple insertion into the central hole of the current bar. Easy indication of the non-connected blocks : simply cut out the notches placed on top of the plastic body of the jumper bar (orange color). Marking with adhesive markers RB5A (marking mode 21). Compatible with test plug FC2.

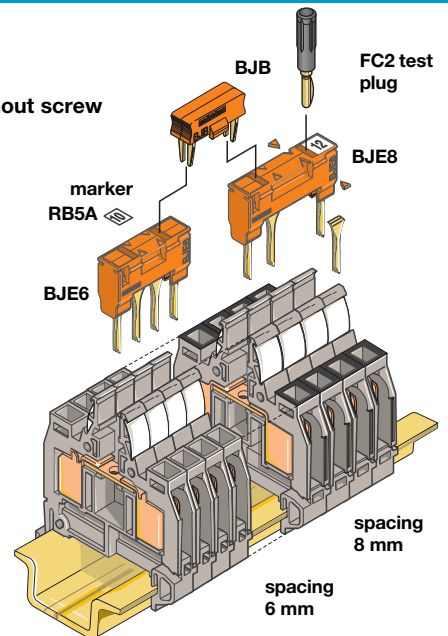

For the mounting of these accessories on blocks with partitions, cut out the partition between two interconnected blocks.

- | BJE6 For blocks spacing 6 mm .238" | | | BJE8 For blocks spacing 8 mm .315" | | |
|------------------------------------|----------|--------------------|------------------------------------|----------|--------------------|
| BJE6.2 | 2 poles | 0299 694.04 | BJE8.2 | 2 poles | 0299 712.05 |
| BJE6.3 | 3 poles | 0299 695.05 | BJE8.3 | 3 poles | 0299 713.06 |
| BJE6.4 | 4 poles | 0299 696.06 | BJE8.4 | 4 poles | 0299 714.07 |
| BJE6.5 | 5 poles | 0299 697.07 | BJE8.5 | 5 poles | 0299 715.00 |
| BJE6.6 | 6 poles | 0299 698.10 | BJE8.6 | 6 poles | 0299 716.01 |
| BJE6.7 | 7 poles | 0299 699.11 | BJE8.7 | 7 poles | 0299 717.02 |
| BJE6.8 | 8 poles | 0299 700.26 | BJE8.8 | 8 poles | 0299 718.13 |
| BJE6.9 | 9 poles | 0299 701.13 | BJE8.9 | 9 poles | 0299 719.14 |
| BJE6.10 | 10 poles | 0299 702.14 | BJE8.10 | 10 poles | 0299 720.11 |

Current capacity : 32 A

Current capacity : 41 A

Short duration current capacity : 300 A/1s
Touch proof : IP20
Fire resistance : UL94 V0

Compatible with following terminal blocks :

- M 4/6 ■ M 6/8.D2 ■ D 2,5/8.ADO ■ D 4/6.ADO.T2
- M 4/6.1 ■ 6/8.D2.1 ■ D 2,5/8.ADO.1 ■ D 4/8.ADO
- M 4/6.T ■ D,5/6.ADO ■ D 4/6.ADO ■ D 6/8.ADO
- M 6/8 ■ D 1,5/6.ADO.1 ■ D 4/6.ADO.1 ■ D 6/8.ADO.1
- M 6/8.1 ■ D 1,5/6.D2.ADO ■ D 4/6.D2.ADO ■ D 6/8.ADO3
- D 1,5/6.D2.ADO.1 ■ D 4/6.D2.ADO.1

✓ for MA 2,5/5, MA 2,5/5.1* , D 1/5.ADO and D 2,5/5.ADO blocks

- | BJE5 | | |
|----------------|----------|--------------------|
| BJE5.2 | 2 poles | 0199 227.23 |
| BJE5.3 | 3 poles | 0199 228.04 |
| BJE5.4 | 4 poles | 0199 298.03 |
| BJE5.5 | 5 poles | 0199 299.04 |
| BJE5.6 | 6 poles | 0299 861.03 |
| BJE5.7 | 7 poles | 0299 862.04 |
| BJE5.8 | 8 poles | 0299 863.05 |
| BJE5.9 | 9 poles | 0299 864.06 |
| BJE5.10 | 10 poles | 0199 443.24 |

Current capacity : 20 A

Marking with adhesive markers

* Cut out the partition for mounting of this accessory

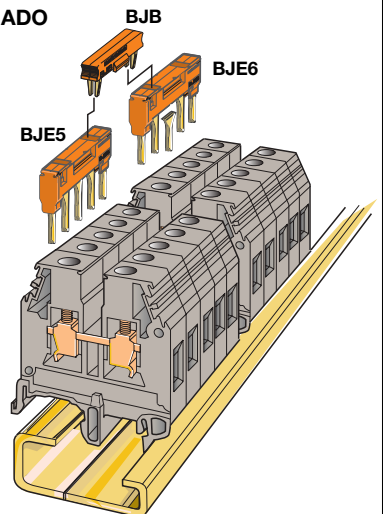

This accessory permits connecting several BJE 5, BJE6, or BJE8 beyond 10 poles and to connect 1 BJE6 with 1 BJE8 (different spacings).

- BJB** **0199 466.23**

AD

IDC jumper (insulation displacement jumper)

AD 2,5

Quick-jump lets you interconnect screw clamp terminals of different sizes, levels, and all manufacturers quickly and safely. Its insulation displacement technology makes it easy to use, fast, economical and does not require a special tool. Use as a jumper between relays, switches, and other electronic components. Entrelec Quick-jump will fit any screw clamp type terminal block, from 6 mm .238" spacing and larger.

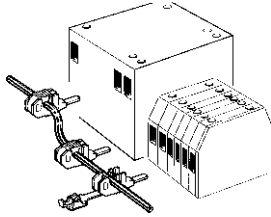

AD 2,5

0114 205.20



Characteristics

Wire size

	IEC		UL	CSA
	NFC	DIN		
Solid wire	2,5 mm ²			14 AWG
Stranded wire	2,5 mm ²			14 AWG

Voltage

Rated	600 V	600 V
Pulse		
Pollution degree		

Current

Rated	26 A	15 A
-------	------	------

Wire size

Rated / Gauge	2,5 mm ²	14 AWG
---------------	---------------------	--------

	Working temperature		Protection
	-55°C to +110°C	-55°C to +110°C	
			IP 20
			NEMA 1

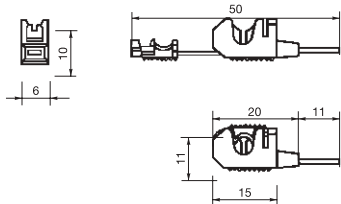

How to use : connecting Quick-jump to your terminal

- 1 - Insert Entrelec Quick-jump into your terminal screw clamp.
- 2 - Tighten the terminal screw.
- 3 - Guide jumper wire through the V-shaped opening in the Quick-jump.
- 4 - Secure the wire by closing the Quick-jump lever with any flat nose pliers.

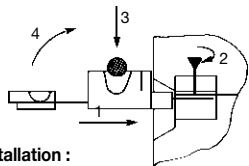

Adding a shunt in an installation :

- 1 - Insert Entrelec Quick-jump into your terminal screw clamp.
- 2 - Guide the terminal screw clamp into contact with the wire.
- 3 - Secure the wire by closing the Quick-jump lever with any flat nose pliers.
- 4 - Tighten the terminal screw.

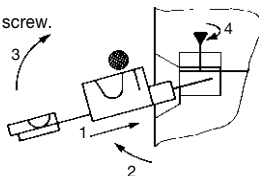

PC

Comb-type jumper bar

PC

EIP

This accessory can be used only on terminal blocks with at least one compression clamp connection. It permits the electrical connection of 2 to 10 blocks.

Interconnection of nonconsecutive blocks is possible by removing the teeth opposite the blocks which must not be connected. The comb-type jumper bars can be cut using pliers (or a saw) : in this case, the use of an insulating tip **EIP** is recommended where possible ; otherwise, use an **SCF** separator or **FE** end section between two series of interconnected blocks in order to preserve insulation. The comb is placed in the compression clamp before tightening the screws, above the eventual conductor.

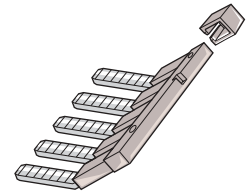
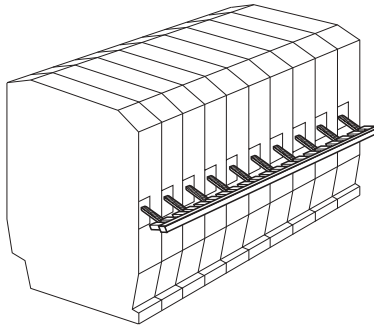
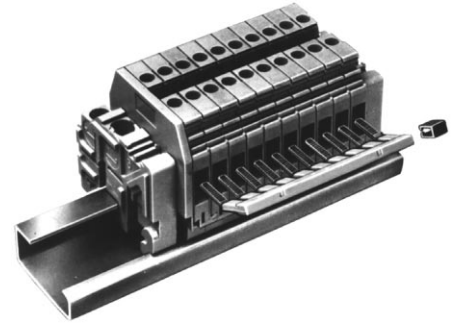

To be mounted on blocks	Insulating tip for comb		Comb-type jumper bar			
	Type	P/N	No. of poles	Type	Current	P/N
MA 2,5/5...	EIP	0113 550.24	2	PC5	30 A	0113 542.10
MA 2,5/5.D...			10	PC5	30 A	0113 544.12
DR 1,5/5...			10	PC51		0167 908.06
M 4/6 - MS 4/6 - M 4/6.H	EIP	0113 550.24	2	PC6	35 A	0113 546.14
M 1,5/6.HH - M 4/6.M2			3	PC6	35 A	0116 536.05
M 4/6.G			4	PC6	35 A	0116 537.06
			10	PC6	35 A	0113 548.26
M 4/6.D - M4/6.S...			10	PC61	35 A	0163 311.22
DR 4/6, DR 2,5/6, DRP 4/6						
M 6/8 - M 6/8.S...			2	PC8	50 A	0116 538.17
			3	PC8	50 A	0116 539.10
			4	PC8	50 A	0116 540.25
			10	PC8	50 A	0163 313.24
M 4/8.S...			10	PC81	35 A	0173 523.11
M 10/10			10	PC10	70 A	0163 315.26
M 10/13.S...			10	PC13	70 A	0173 510.20
MB 10/22.S...			3	PC22	70 A	0205 295.06
			10	PC22	70 A	0174 151.25
M 10/16.SF	EIP	0113 550.24	2	PC16	70 A	0116 729.26
			3	PC16	70 A	0116 733.12
			4	PC16	70 A	0116 734.13
			10	PC16	70 A	0116 735.14
Series 7 000 or 8 000			10	PC9	15 A	0210 160.12

BP8.A4

Bridging plug

This accessory permits electrical connection of 2 identical juxtaposed blocks. These blocks have 8 mm / .315" spacing, are equipped with a test socket dia 4 / .16".

BP8.A4

0173 888.20

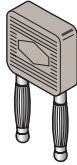

BNSTP...

Short-circuiting plug

Shunt equipped with 2 plugs dia. 4 mm / .16" for ES16 and M6/8.STP blocks.
Rated voltage : 600 V
Rated current : 20 A
2 versions available :

✓ with test socket dia. 4 mm / .16" :
Light ivory

BNSTP1 **0196 792.17**

Grey
BNSTP1 **0196 793.10**

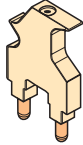

✓ without test socket:
Red

BNSTP2 **0196 789.24**

Grey
BNSTP2 **0196 790.21**



CB

Shield connector

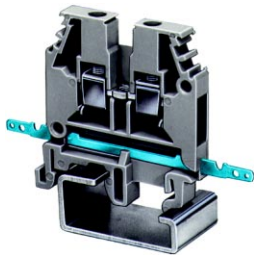

Delivered separately, this bar of treated brass is mounted in the lower part of the terminal block. It ensures the continuity of the shield connection. The connection to the shield connector can be made either by soldering or by 2,8x0,5 mm or 2,8x0,8 mm quick connect tabs.

Notch available for bridging all shieldings. This accessory overlaps on each side of the block by about 13,5 mm.

Use of this bar reduces insulation between terminal and ground, working voltage must be derated (consult us if necessary).

CBD5.2L	0291 077.24
CBM5D	0173 530.24
CBD2S	0178 408.14
CBD2	0179 635.07
CBD1	0179 634.06
CBM8	0178 746.15
CBM5	0178 745.14

EP

Protection label

Indicates live circuits, prohibiting access to the connection screws. This accessory also protects the connections from dust and from touch.

EP...

Covers 3 or 4 blocks.
The color of the label is yellow with a red arrow. It can be fixed using 2 nylon screws (VSP ...) to be ordered separately.

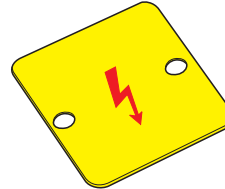
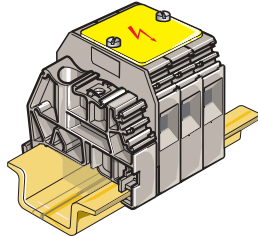

Type of blocks	Number of blocks	Type	Part number	Type	Part number
M 4/6	4	EP6	0163 427.17	VSP6	0163 433.15
M 6/8	3	EP6	0163 427.17	VSP6	0163 433.15
	4	EP8	0163 428.20	VSP6	0163 433.15
M 10/10	3	EP8	0163 428.20	VSP6	0163 433.15
	4	EP10	0163 429.21	VSP6	0163 433.15
M 16/12	3	EP10	0163 429.21	VSP12	0163 432.14
	4	EP12	0163 430.26	VSP12	0163 432.14
M 35/16	3	EP12	0163 430.26	VSP16	0173 147.20
	4	EP16	0163 431.13	VSP16	0173 147.20
M 70/22	3	EP223	0173 327.24	VSP22	0173 323.20
	4	EP224	0173 328.05	VSP22	0173 323.20

EPU ...

Covers 1 block.
The color of the label is yellow with a black arrow, to be snapped directly on the terminal block.

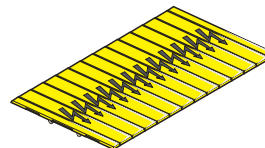
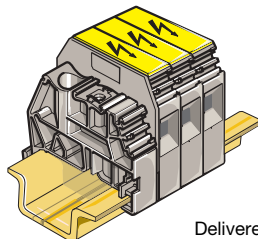

Delivered in cards of 12 labels.

Type of blocks	Type	Part number
MA 2,5/5	EPU5	0107 033.10
M 4/6, M 6/8, M 10/10, M 16/12*	EPU6	0107 038.25

(*) : use 2 labels EPU 6 for blocks spacing 12 mm.

VSP

Screw for protection label

VSP...

Two nylon screws used to hold down one protection label. Each is installed into the tapped hole on each of the two outside blocks.

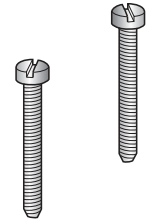

EL

Connector plate

This accessory is used for connecting electrically : two assembled interconnections with same spacing or two assembled interconnections with different spacings. Use only between the 5 mm .200" spacing, 6 mm .238" spacing and 8 mm .315" spacing blocks



EL6 **0173 627.21**
EL61 **0177 812.17**

For **D 2,5/6.D...** blocks



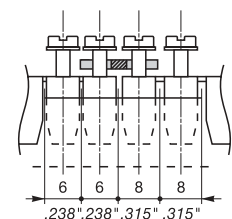
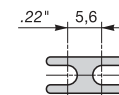

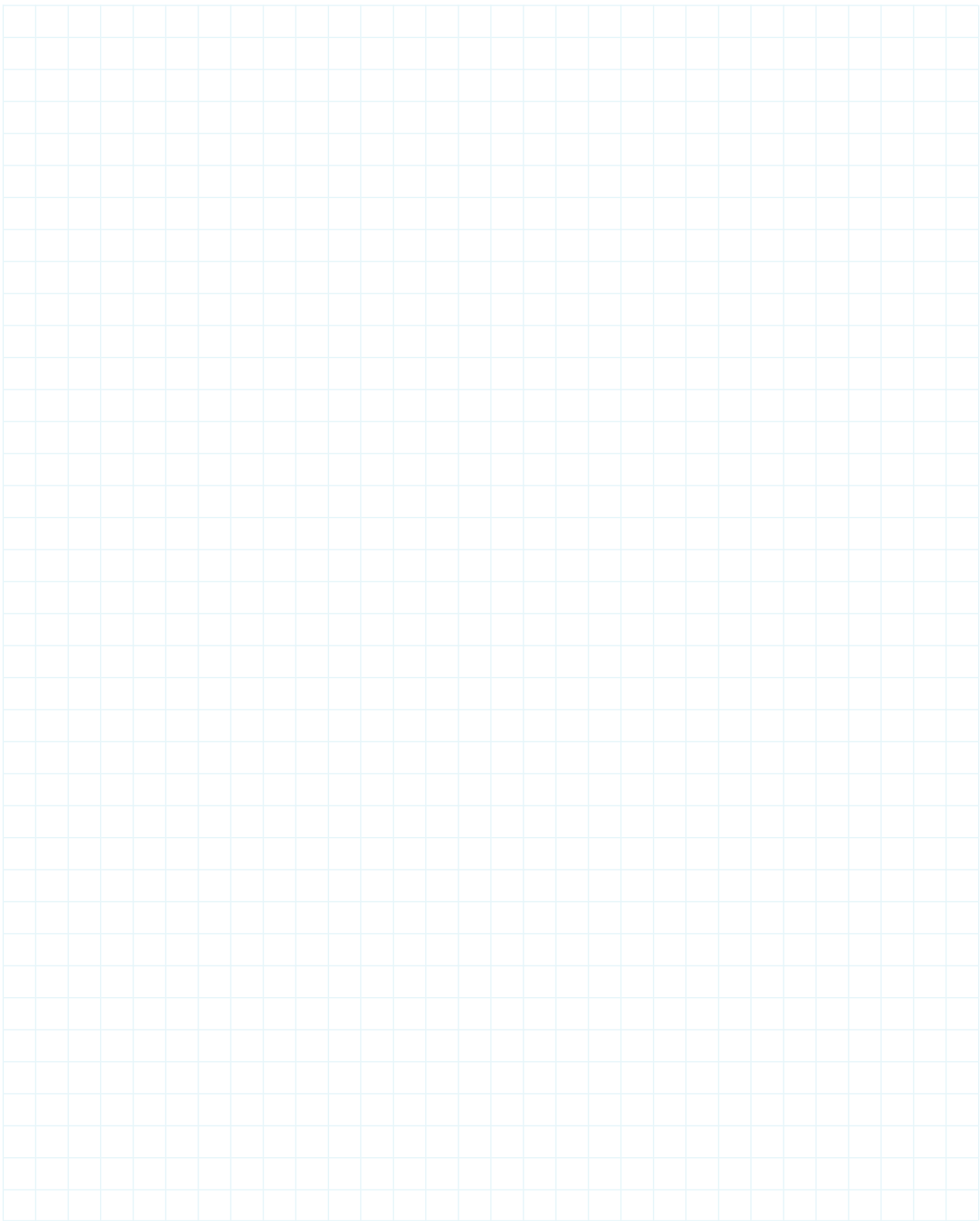



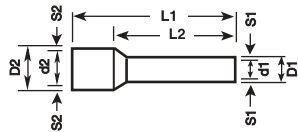

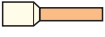





Current carrying capacity : 35 A





FERRULES

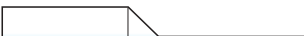

Insulated ferrules	Wire size		Type	Color	Minimum order quantity	Dimensions (mm)*								P/N
	mm ²	AWG				L1	L2	d1	S1	d2	S2	D1	D2	
	0.5	22	short	white	1,000	14.0	8.0	1.0	0.15	2.6	0.25	1.3	3.1	0304 454.00
	0.75	20	short	grey	1,000	14.0	8.0	1.2	0.15	2.8	0.25	1.5	3.3	0304 455.01
	1	18	short	red	1,000	14.0	8.0	1.4	0.15	3.0	0.25	1.7	3.5	0304 456.02
	1.5	16	short	black	1,000	14.0	8.0	1.7	0.15	3.5	0.25	2.0	4.0	0304 457.03
	1.5	16	long	black	1,000	24.0	18.0	1.7	0.15	3.5	0.25	2.0	4.0	0304 458.14
	2.5	14	short	blue	1,000	14.0	8.0	2.2	0.15	4.2	0.25	2.5	4.7	0304 459.15
	2.5	14	long	blue	1,000	24.0	18.0	2.2	0.15	4.2	0.25	2.5	4.7	0304 460.12
	4	12	short	grey	1,000	17.0	10.0	2.8	0.20	4.8	0.30	3.2	5.4	0304 461.07
	4	12	long	grey	1,000	26.0	18.0	2.8	0.20	4.8	0.30	3.2	5.4	0304 462.00
	6	10	short	yellow	100	20.0	12.0	3.5	0.20	6.3	0.30	3.7	6.9	0304 463.01
	6	10	long	yellow	100	26.0	18.0	3.5	0.20	6.3	0.30	3.7	6.9	0304 464.02
	10	8	short	red	100	22.0	12.0	4.5	0.20	7.6	0.40	4.9	8.4	0304 465.03
	10	8	long	red	100	28.0	18.0	4.5	0.20	7.6	0.40	4.9	8.4	0304 466.04
	16	6	short	blue	100	24.0	12.0	5.8	0.20	8.8	0.40	6.2	9.6	0304 467.05
	16	6	long	blue	100	28.0	18.0	5.8	0.20	8.8	0.40	6.2	9.6	0304 468.16
	25	4	short	yellow	100	30.0	18.0	7.3	0.20	11.2	0.40	7.7	12.0	0304 469.17
	35	2	short	red	50	30.0	18.0	8.3	0.20	12.7	0.40	8.7	13.5	0304 470.14
	50	0	short	blue	50	40.0	25.0	10.3	0.30	15.0	0.50	10.9	16.0	0304 471.01

*Dimensions may vary slightly from one shipment to the next. See page 1924 for ferrule crimping tools.

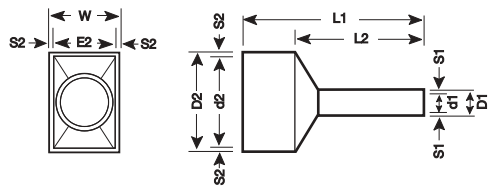

FERRULES

Insulated twin ferrules	Wire size		Color	Strip length	Dimensions (mm)*								P/N
	mm ²	AWG			L1	L2	d1	S1	E2/d2	S2	D1	W/D2	
	2 x 0.5	2 x 22	White	5.2	15.0	8.0	1.50	0.15	2.5/4.7	0.25	1.80	3.0/5.2	0304 558.10
	2 x 0.75	2 x 20	Grey	5.5	15.0	8.0	1.80	0.15	2.8/5.0	0.25	2.10	3.3/5.5	0304 559.11
	2 x 0.75	2 x 20	Grey	5.5	17.0	10.0	1.80	0.15	2.8/5.0	0.25	2.10	3.3/5.5	0304 560.16
	2 x 1.0	2 x 18	Red	6.0	15.0	8.0	2.05	0.15	3.4/5.4	0.30	2.35	4.0/6.0	0304 561.03
	2 x 1.0	2 x 18	Red	6.0	17.0	10.0	2.05	0.15	3.4/5.4	0.30	2.35	4.0/6.0	0304 562.04
	2 x 1.5	2 x 16	Black	7.2	16.0	8.0	2.30	0.15	3.6/5.6	0.30	2.60	4.2/7.2	0304 563.05
	2 x 1.5	2 x 16	Black	7.2	20.0	12.0	2.30	0.15	3.6/5.6	0.30	2.60	4.2/7.2	0304 564.06
	2 x 2.5	2 x 14	Blue	8.4	18.5	10.0	2.90	0.20	4.2/7.8	0.30	3.30	4.8/8.4	0304 565.07
	2 x 2.5	2 x 14	Blue	8.4	21.5	13.0	2.90	0.20	4.2/7.8	0.30	3.30	4.8/8.4	0304 566.00
	2 x 4.0	2 x 12	Grey	9.4	23.0	12.0	3.80	0.20	4.9/8.8	0.30	4.20	5.5/9.4	0304 567.01
	2 x 6.0	2 x 10	Yellow	10.8	26.0	14.0	4.90	0.20	6.9/10.0	0.40	5.30	7.7/10.8	0304 568.12
	2 x 10.0	2 x 8	Red	13.8	26.0	14.0	6.50	0.20	7.2/13.0	0.40	6.90	8.0/13.8	0304 569.13
	2 x 16.0	2 x 6	Blue	19.2	30.0	14.0	8.30	0.20	9.6/18.4	0.40	8.70	10.4/19.2	0304 570.10

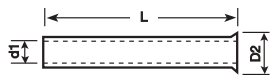

Uninsulated ferrules	Wire size		Strip length	Dimensions (mm)*			P/N
	mm ²	AWG		L	d1	D2	
	0.5	22	5.5	6	1.0	2.1	0304 571.05
	0.75	20	5.5	6	1.4	2.5	0304 572.06
	1.0	18	5.5	6	1.6	2.7	0304 573.07
	1.0	18	8.5	10	1.6	2.7	0304 574.00
	1.5	16	6.0	7	1.8	2.9	0304 575.01
	1.5	16	9.0	10	1.8	2.9	0304 576.02
	2.5	14	6.0	7	2.3	3.5	0304 577.03
	2.5	14	11.0	12	2.3	3.5	0304 578.14
	4.0	12	8.0	9	2.8	4.0	0304 579.15
	4.0	12	11.0	12	2.8	4.0	0304 580.03
	6.0	10	9.0	10	3.7	4.8	0304 581.20
	6.0	10	11.0	12	3.7	4.8	0304 582.21
	6.0	10	14.0	15	3.7	4.8	0304 583.22
	10.0	8	11.0	12	4.6	5.8	0304 584.23
	10.0	8	14.0	15	4.6	5.8	0304 585.24
	10.0	8	17.0	18	4.6	5.8	0304 586.25
	16.0	6	10.5	12	5.9	7.5	0304 587.26
	16.0	6	13.5	15	5.9	7.5	0304 588.07
	16.0	6	16.5	18	5.9	7.5	0304 589.00

*Dimensions may vary slightly from one shipment to the next. See page 1924 for ferrule crimping tools.

FLAT BLADE INSULATED FERRULES

Insulated ferrules	Wire size		Color	Minimum order quantity	Dimensions (mm)*				P/N
	mm ²	AWG			A	B	C	L	
	0.25 - 1.5	22 - 16	Red	100	3	13	1.8	22	0305 714.05
	1.5 - 2.5	16 - 14	Blue	100	3	14	2.3	24.5	0305 715.06
	2.5 - 6	14 - 10		100	4	13	3.6	30	0305 716.07

* Dimensions may vary slightly from one shipment to the next.

Features

- Easy crimping with standard ratchet or plier type crimping tool.
- Serrated blade assures retention by wire clamp.
- Funnel shaped insulation facilitates wire entry.



FERRULE CRIMPING TOOLS

Features

- Heavy duty, industrial grade tool.

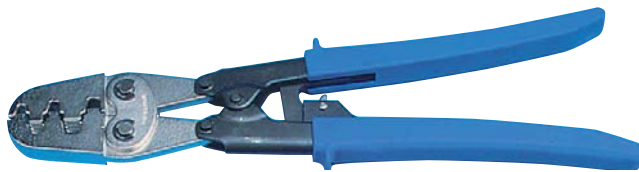

Crimping tool, ferrule wire range 8 to 1 AWG

P/N **0304 441.03**

- All purpose, economy tool.



Crimping tool, ferrule wire range 22 to 10 AWG

P/N **0305 626.05**

Crimping tool, ferrule wire range 10 to 6 AWG

P/N **0305 627.06**

- Heavy duty, industrial grade tool.



Crimping tool, ferrule wire range 28 to 10 AWG

P/N **0304 439.01**





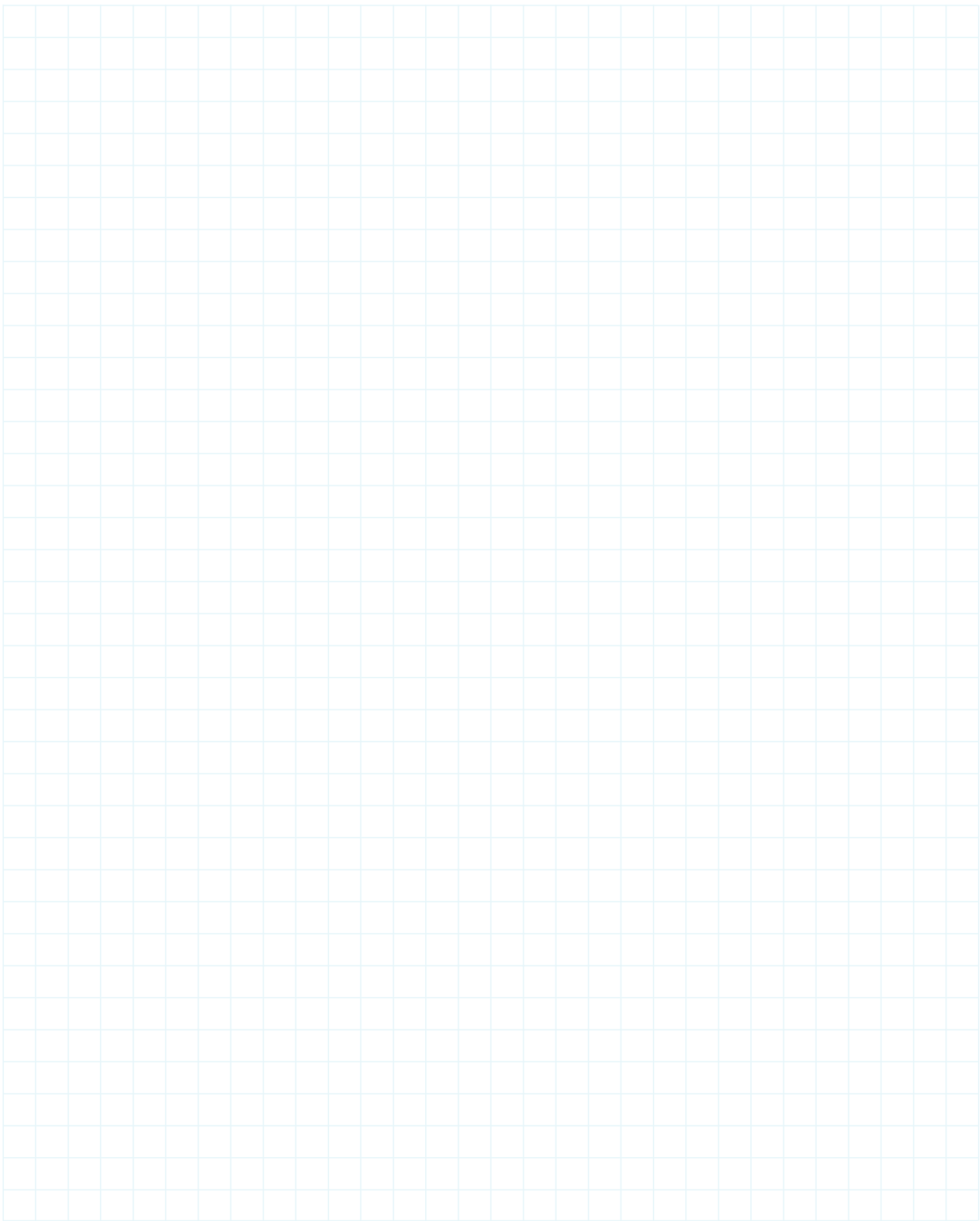

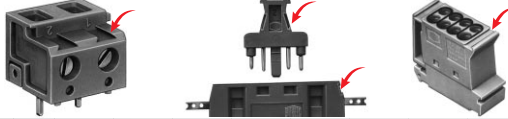
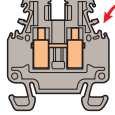

Crimping tool, ferrule wire range 14 to 8 AWG

P/N **0304 440.16**

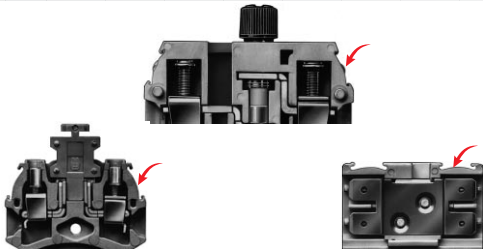

Terminal block marking

Marking
method

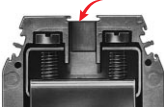
<p>1 <i>Molded pre-marking</i></p>	
<p>2 <i>Slot for markers</i></p>	
<p>3 <i>Slot for markers – 4 mm spacing (RC 410)</i></p>	
<p>4 <i>Slot for markers – 5,08 mm spacing</i></p>	
<p>5 <i>Slot for markers (RC 55 - RC 65)</i></p>	
<p>6 <i>Slot for markers (RC 610)</i></p>	
<p>7 <i>Slot for markers (length 20 mm)</i></p>	
<p>8 <i>Slot for PE 25 marker-holder</i></p>	
<p>9 <i>Slot for PE 207 marker-holder</i></p>	
<p>10 <i>Slot for markers – 5 mm spacing (RC 55 - RC 510)</i></p>	
<p>11 <i>Slot for markers – 6 mm & more spacing (RC 65 - RC 610)</i></p>	
<p>12 <i>Slot for central markers (width 7,5 mm)</i></p>	
<p>13 <i>Slot for central markers (width 9,6 mm)</i></p>	

Pages 1926-27 list 26 marking methods to use with Entrelec terminal blocks. To find the marking method to use with the block of your interest, follow these steps:

1. Find the word "Accessories", near the bottom of the page on which the block is described.
2. Below "Accessories", find the words "See markers...marking method."
3. The circled number is the marking method for the block located in the same column, at the top of the page.

Marking
method

<p>14 <i>Slot for sticker</i> (25 x 3,5 mm)</p>	
<p>15 <i>Slot for PEP marker-holder</i></p>	
<p>16 <i>Slot for markers – series 10 000 & 11 000 blocks</i></p>	
<p>17 <i>Slot for markers – 8 mm spacing (RC 810)</i></p>	
<p>18 <i>Slot for sticker</i> (7 x 5 mm)</p>	
<p>19 <i>Slot for sticker</i> (10 x 2,8 mm)</p>	
<p>20 <i>Slot for typesetting markers</i></p>	
<p>21 <i>Marking with adhesive strips</i> (width 5 mm)</p>	
<p>22 <i>Marking with adhesive strips</i> (width 3 mm)</p>	
<p>23 <i>Slot for markers</i> (spacing 5,08 mm)</p>	
<p>24 <i>Slot for markers – series 8 000, 10 000 & 30 000 blocks</i></p>	
<p>25 <i>Slot for markers – spring & ADO blocks</i></p>	
<p>26 <i>Slot for markers – 10 mm spacing (RC 1010)</i></p>	

RC Standard marker cards

Each marker card contains 10 strips of 10 markers, i.e. 100 markers per card.

Marker cards are white polyamide 6 with black lettering.

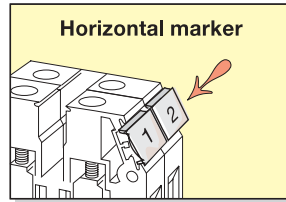

Horizontal marker See page 1930 for most popular.

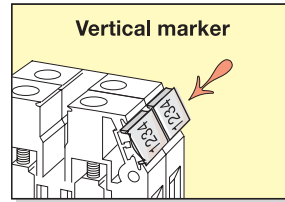

Vertical marker See page 1933 for most popular.

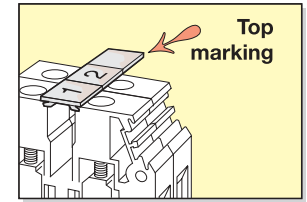

Top marking See page 1937.

How to use

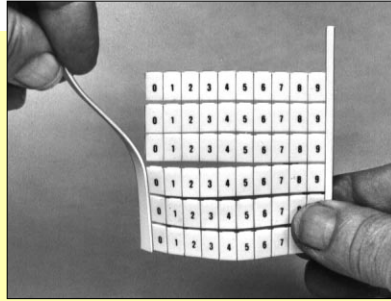

1

Remove one of the side bands of the card.

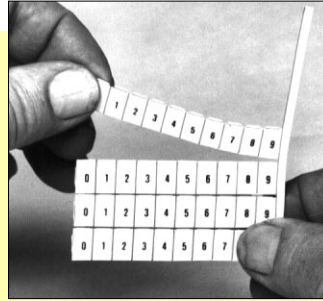

2

Separate the chosen strip from the rest of the card.

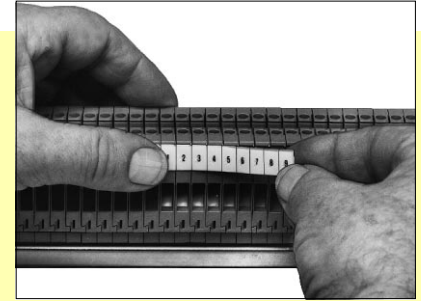

3

- Strips of 10 markers for block spacings 5 mm .197", 6 mm .236" and 8 mm .315": Press the first marker in place, hold it and slide your thumb on the rest of the strip to snap each marker on the terminal block assembly.
- Single markers : Press the chosen marker in place, hold it and tear off the rest of the strip.

Marker sizes

RC55
5 x 5 mm markers
.197" x .197".
Can be used on blocks from 5 mm .197" spacing, with possibility of mounting 2 markers per slot.

RC65
6 x 5 mm markers
.236" x .197".
Can be used on blocks from 6 mm .236" spacing, with possibility of mounting 2 markers per slot.

RCAL85
8 x 5 mm markers
.315" x .197".
Can be used on 8 mm .315" spacing spring connection blocks & mini ADO blocks.

RC410
4 x 10 mm markers
.157" x .394".
Can be used on blocks from 4 mm .157" spacing, 1 marker per slot.

RC510
5 x 10 mm markers
.197" x .394".
Can be used on blocks from 5 mm .197" spacing, 1 marker per slot.

RC610
6 x 10 mm markers
.236" x .394".
Can be used on blocks from 6 mm .236" spacing, 1 marker per slot.

RC810
8 x 10 mm markers
.315" x .394".
Can be used on blocks from 8 mm .315" spacing, 1 marker per slot.

RC1010
10 x 10 mm markers
.394" x .394".
Can be used on blocks from 10 mm .394" spacing, 1 marker per slot.

The marker that goes into the terminal block slot for each marking method is listed here :

Marker	Marking method
RC410	③
RC55	⑤ ⑩
RC510	⑥ ⑩
RC65	⑤ ⑪
RC610	⑥ ⑪
RCAL85	⑫
RC810	⑰
RC1010	⑲

Standard marker cards	Marker width mm	Marker height, L mm	Use with terminal block thickness
RC410	4	10	4 mm
RC55	5	5	5 mm
RC510	5	10	5 mm
RC65	6	5	6 mm
RC610	6	10	6 mm
RCAL85	8	5	8 mm
RC810	8	10	8 mm and larger
RC1010	10	10	10 mm and larger

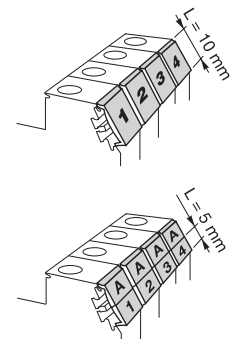

Blank marker cards	RC410	RC55	RC510	RC65
	white 0229 000.15	white 0230 000.12	white 0231 000.07	red 0103 776.01 blue 0103 775.00 white 0232 000.00
Mürplastik markers for terminal blocks	RC610	RCAL85	RC810	RC1010
	white 0233 000.01 green 0206 230.11 yellow 0206 231.06 orange 0206 232.07	blue 0206 233.00 purple 0206 234.01 red 0206 235.02	white 0237 000.05	white 0234 000.02 white 0238 000.16
	RC510A	RC610A	RC810A	
	white 0231 500.01	white 0233 500.03	white 0234 500.04	

Card holder for item above 0205 462.05

RC Standard marker cards (cont.)

Horizontal marking of numbers

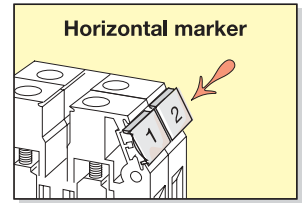
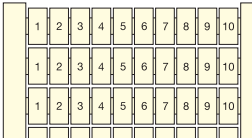

Horizontal marking
Repeated increasing order 10 times

RC55		RC510		RC65		RC610		RC810	
0 → 9	0230 001.07	0 → 9	0231 001.24	0 → 9	0232 001.25	0 → 9	0233 001.26	0 → 9	0234 001.27
1 → 10	0230 002.00	1 → 10	0231 002.25	1 → 10	0232 002.26	1 → 10	0233 002.27	1 → 10	0234 002.20
11 → 20	0230 003.01	11 → 20	0231 003.26	11 → 20	0232 003.27	11 → 20	0233 003.20	11 → 20	0234 003.21
21 → 30	0230 004.02	21 → 30	0231 004.27	21 → 30	0232 004.20	21 → 30	0233 004.21	21 → 30	0234 004.22
31 → 40	0230 005.03	31 → 40	0231 005.20	31 → 40	0232 005.21	31 → 40	0233 005.22	31 → 40	0234 005.23
41 → 50	0230 006.04	41 → 50	0231 006.21	41 → 50	0232 006.22	41 → 50	0233 006.23	41 → 50	0234 006.24
51 → 60	0230 007.05	51 → 60	0231 007.22	51 → 60	0232 007.23	51 → 60	0233 007.24	51 → 60	0234 007.25
61 → 70	0230 008.16	61 → 70	0231 008.03	61 → 70	0232 008.04	61 → 70	0233 008.05	61 → 70	0234 008.06
71 → 80	0230 009.17	71 → 80	0231 009.04	71 → 80	0232 009.05	71 → 80	0233 009.06	71 → 80	0234 009.07
81 → 90	0230 010.03	81 → 90	0231 010.20	81 → 90	0232 010.21	81 → 90	0233 010.22	81 → 90	0234 010.23
91 → 100	0230 011.20	91 → 100	0231 011.15	91 → 100	0232 011.16	91 → 100	0233 011.17	91 → 100	0234 011.10
101 → 110	0230 012.21	101 → 110	0231 012.16	101 → 110	0232 012.17	101 → 110	0233 012.10	101 → 110	0234 012.11
111 → 120	0230 013.22	111 → 120	0231 013.17	111 → 120	0232 013.10	111 → 120	0233 013.11	111 → 120	0234 013.12
121 → 130	0230 014.23	121 → 130	0231 014.10	121 → 130	0232 014.11	121 → 130	0233 014.12	121 → 130	0234 014.13
131 → 140	0230 015.24	131 → 140	0231 015.11	131 → 140	0232 015.12	131 → 140	0233 015.13	131 → 140	0234 015.14
141 → 150	0230 016.25	141 → 150	0231 016.12	141 → 150	0232 016.13	141 → 150	0233 016.14	141 → 150	0234 016.15
151 → 160	0230 017.26	151 → 160	0231 017.13	151 → 160	0232 017.14	151 → 160	0233 017.15	151 → 160	0234 017.16
161 → 170	0230 018.07	161 → 170	0231 018.24	161 → 170	0232 018.25	161 → 170	0233 018.26	161 → 170	0234 018.27
171 → 180	0230 019.00	171 → 180	0231 019.25	171 → 180	0232 019.26	171 → 180	0233 019.27	171 → 180	0234 019.20
181 → 190	0230 020.05	181 → 190	0231 020.22	181 → 190	0232 020.23	181 → 190	0233 020.24	181 → 190	0234 020.25
191 → 200	0230 021.22	191 → 200	0231 021.17	191 → 200	0232 021.10	191 → 200	0233 021.11	191 → 200	0234 021.12
201 → ...	} 0230 022.23*	201 → ...	} 0231 022.10*	201 → ...	} 0232 022.11*	201 → ...	} 0233 022.12	201 → ...	} 0234 022.13*
... → 999		... → 999		... → 999		... → 999		... → 999	

Markers	Marking method	Marker width mm	Marker height, L mm	Use with terminal block thickness
RC55	⑤ ⑩	5	5	5 mm
RC510	⑥ ⑩	5	10	5 mm
RC65	⑤ ⑪	6	5	6 mm
RC610	⑥ ⑪	6	10	6 mm
RC810	⑥ ⑰	8	10	8 mm and larger

* Part numbers identical for each group of numbers : on request (indicate marking)
Ex. : 0230 022.23 : 301 to 310.

31 → 40	0233 005.22
41 → 50	0233 006.23
51 → 60	0233 007.24
61 → 70	0233 008.05
71 → 80	0233 009.06
81 → 90	0233 010.22
91 → 100	0233 011.17
101 → 110	0233 012.10
111 → 120	0233 013.11
121 → 130	0233 014.12
131 → 140	0233 015.13
141 → 150	0233 016.14
151 → 160	0233 017.15
161 → 170	0233 018.26
171 → 180	0233 019.27
181 → 190	0233 020.24
191 → 200	0233 021.11
201 → 210	0233 022.12
211 → 220	0233 023.13
221 → 230	0233 024.14
231 → 240	0233 025.15
241 → 250	0233 026.16
251 → 260	0233 027.17
261 → 270	0233 028.20
271 → 280	0233 029.21
281 → 290	0233 030.23
291 → 300	0233 031.10
301 → 310	0233 032.11
311 → 320	0233 033.12
321 → 330	0233 034.13
331 → 340	0233 035.14
341 → 350	0233 036.15
351 → 360	0233 037.16
361 → 370	0233 038.27
371 → 380	0233 039.20
381 → 390	0233 040.02
391 → 400	0233 041.27
401 → 410	0233 042.20
411 → 420	0233 043.21
421 → 430	0233 044.22
431 → 440	0233 045.23
441 → 450	0233 046.24
451 → 460	0233 047.25
461 → 470	0233 048.06
471 → 480	0233 049.07
481 → 490	0233 050.23
491 → 500	0233 051.25
501 → ...	} 0233 121.12*
... → 999	

RC Standard marker cards (cont.)

Horizontal marking of numbers (cont.)

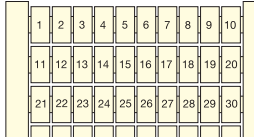

MOST POPULAR

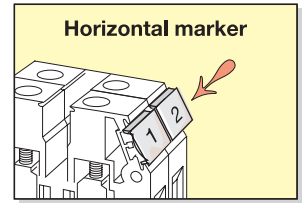

Horizontal marker
For vertical markers, see page 1933.

Horizontal marking
Increasing order

RCAL85

1 → 100 **0237 030.22**
See page 1936.

RC55		RC510		RC65		RC610		RC810	
1 → 100	0230 030.07	1 → 100	0231 030.24	1 → 100	0232 030.25	1 → 100	0233 030.26	1 → 100	0234 030.27
101 → 200	0230 031.24	101 → 200	0231 031.11	101 → 200	0232 031.12	101 → 200	0233 031.13	101 → 200	0234 031.14
201 → 300	0230 032.25	201 → 300	0231 032.12	201 → 300	0232 032.13	201 → 300	0233 032.14	201 → 300	0234 032.15
301 → 400	0230 033.26	301 → 400	0231 033.13	301 → 400	0232 033.14	301 → 400	0233 033.15	301 → 400	0234 033.16
401 → 500	0230 034.34	401 → 500	0231 034.14	401 → 500	0232 034.15	401 → 500	0233 034.16	401 → 500	0234 034.17
501 → 600	0230 035.20	501 → 600	0231 035.15	501 → 600	0232 035.16	501 → 600	0233 035.17	501 → 600	0234 035.10
601 → 700	0230 036.21	601 → 700	0231 036.16	601 → 700	0232 036.17	601 → 700	0233 036.10	601 → 700	0234 036.11
701 → 800	0230 037.22	701 → 800	0231 037.17	701 → 800	0232 037.10	701 → 800	0233 074.26	701 → 800	0234 037.12
801 → 900	0230 038.03	801 → 900	0231 038.20	801 → 900	0232 038.21	801 → 900	0233 075.27	801 → 900	0234 038.23
901 → 1000	0230 039.04	901 → 1000	0231 039.21	901 → 1000	0232 039.22	901 → 1000	0233 076.20	901 → 1000	0234 039.24
1001 →	0230 071.04*	1001 →	0231 071.21*	1001 →	0232 071.22*	1001 →	0233 073.25*	1001 →	0234 071.24*

* Part numbers identical for each group of numbers : on request (indicate marking). Ex. : 0230 071.04 : 1001 to 1100.

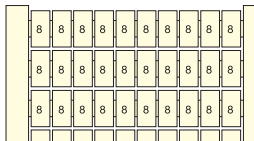

Horizontal marking
Repeated identical numbers

Markers	Marking method	Marker width mm	Marker height, L mm	Use with terminal block thickness
RC55	⑤ ⑩	5	5	5 mm
RC510	⑥ ⑩	5	10	5 mm
RC65	⑤ ⑪	6	5	6 mm
RC610	⑥ ⑪	6	10	6 mm
RC810	⑥ ⑰	8	10	8 mm and larger

RC55		RC510		RC65		RC610	
100 x 0	0230 240.26	100 x 0	0231 210.05	100 x 0	0232 201.02	100 x 0	0233 201.03
100 x 1	0230 241.13	100 x 1	0231 211.22	100 x 1	0232 202.03	100 x 1	0233 202.04
100 x 2	0230 242.14	100 x 2	0231 212.23	100 x 2	0232 203.04	100 x 2	0233 203.05
100 x 3	0230 243.15	100 x 3	0231 213.24	100 x 3	0232 204.05	100 x 3	0233 204.06
100 x 4	0230 244.16	100 x 4	0231 214.25	100 x 4	0232 205.06	100 x 4	0233 205.07
100 x 5	0230 245.17	100 x 5	0231 215.26	100 x 5	0232 206.07	100 x 5	0233 206.00
100 x 6 or 9	0230 246.10	100 x 6 or 9	0231 216.27	100 x 6 or 9	0232 207.00	100 x 6 or 9	0233 207.01
100 x 7	0230 247.11	100 x 7	0231 217.20	100 x 7	0232 208.11	100 x 7	0233 208.12
100 x 8	0230 248.22	100 x 8	0231 218.01	100 x 8	0232 209.12	100 x 8	0233 209.13
100 x 10	0230 250.20	100 x 10	0231 220.07	100 x 10	0232 211.23	100 x 10	0233 211.24
100 x 11	0230 251.15	100 x 11	0231 221.24	100 x 11	0232 212.24	100 x 11	0233 212.25
100 x 12	0230 252.16	100 x 12	0231 222.25	100 x 12	0232 213.25	100 x 12	0233 213.26
100 x 13	0230 253.17	100 x 13	0231 223.26	100 x 13	0232 214.26	100 x 13	0233 214.27
100 x 14	0230 254.10	100 x 14	0231 224.27	100 x 14	0232 215.27	100 x 14	0233 215.20
100 x 15	0230 255.11	100 x 15	0231 225.20	100 x 15	0232 216.20	100 x 15	0233 216.21
100 x 16	0230 256.12	100 x 16	0231 226.21	100 x 16	0232 217.21	100 x 16	0233 217.22
100 x 17	0230 257.13	100 x 17	0231 227.22	100 x 17	0232 218.02	100 x 17	0233 218.03
100 x 18	0230 258.24	100 x 18	0231 228.03	100 x 18	0232 219.03	100 x 18	0233 219.04
100 x 19	0230 259.25	100 x 19	0231 229.04	100 x 19	0232 220.00	100 x 19	0233 220.01
100 x 20	0230 260.22	100 x 20	0231 230.01	100 x 20	0232 221.25	100 x 20	0233 221.26
		100 x ... } 999	0231 231.26*	100 x ... } 999	0232 222.26*	100 x ... } 999	0233 222.27*

* Part numbers identical for each group of numbers : on request (indicate marking). Ex. : 0231 231.26 : 100 x 21.

RC Standard marker cards (cont.)

Horizontal marking of numbers (cont.)

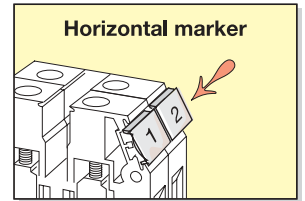

1	3	5	7	9	11	13	15	17	19
2	4	6	8	10	12	14	16	18	20
21	23	25	27	29	31	33	35	37	39

RC65

1	→	20	0232 133.15
21	→	40	0232 134.16
41	→	60	0232 135.17
61	→	80	0232 136.10
81	→	100	0232 137.11

RC610

1	→	20	0233 133.16
21	→	40	0233 134.17
41	→	60	0233 135.10
61	→	80	0233 136.11
81	→	100	0233 137.12

Horizontal marking
Alternate even/odd numbered
for 2 deck block **M 4/6.D**

1	2	3	4	5	6	7	8	9
1	2	3	4	5	6	7	8	9
1	2	3	4	5	6	7	8	9

Horizontal marking
Increasing order repeated 10 times

1	2	3	4	5	6	7	8	9	10
11	12	13	14	15	16	17	18	19	20
21	22	23	24	25	26	27	28	29	30

Horizontal marking
Increasing order 2 times

Markers	Marking method	Marker width mm	Marker height, L mm	Use with terminal block thickness
RC55	⑤ ⑩	5	5	5 mm
RC510	⑥ ⑩	5	10	5 mm
RC65	⑤ ⑪	6	5	6 mm
RC610	⑥ ⑪	6	10	6 mm
RC810	⑥ ⑰	8	10	8 mm and larger

RC610

10 x 1	→	9	0233 142.27
+ blank			

RC610

2 x 1	→	50	0233 141.26
-------	---	----	--------------------

RC810

10 x 1	→	9	0234 130.20
+ blank			

Horizontal marking of letters

A	A	A	A	A	A	A	A	A	A
A	A	A	A	A	A	A	A	A	A
A	A	A	A	A	A	A	A	A	A

Horizontal marking
Repeated identical letters

RC55

100 x A	0230 150.14
100 x B	0230 151.01
100 x C	0230 152.02
100 x D	0230 153.03
100 x E	0230 154.04
100 x F	0230 155.05
100 x G	0230 156.06
100 x H	0230 157.07
100 x I	0230 158.10
100 x J	0230 159.11
100 x K	0230 160.16
100 x L	0230 161.03
100 x M	0230 162.04
100 x N	0230 163.05
100 x O	0230 164.06
100 x P	0230 165.07
100 x Q	0230 166.00
100 x R	0230 167.01
100 x S	0230 168.12
100 x T	0230 169.13
100 x U	0230 170.10
100 x V	0230 171.05
100 x W	0230 172.06
100 x X	0230 173.07
100 x Y	0230 174.00
100 x Z	0230 175.01

RC510

100 x A	0231 150.01
100 x B	0231 151.26
100 x C	0231 152.27
100 x D	0231 153.20
100 x E	0231 154.21
100 x F	0231 155.22
100 x G	0231 156.23
100 x H	0231 157.24
100 x I	0231 158.05
100 x J	0231 159.06
100 x K	0231 160.03
100 x L	0231 161.20
100 x M	0231 162.21
100 x N	0231 163.22
100 x O	0231 164.23
100 x P	0231 165.24
100 x Q	0231 166.25
100 x R	0231 167.26
100 x S	0231 168.07
100 x T	0231 169.00
100 x U	0231 170.05
100 x V	0231 171.22
100 x W	0231 172.23
100 x X	0231 173.24
100 x Y	0231 174.25
100 x Z	0231 175.26

RC65

100 x A	0232 150.02
100 x B	0232 151.27
100 x C	0232 152.20
100 x D	0232 153.21
100 x E	0232 154.22
100 x F	0232 155.23
100 x G	0232 156.24
100 x H	0232 157.25
100 x I	0232 158.06
100 x J	0232 159.07
100 x K	0232 160.04
100 x L	0232 161.21
100 x M	0232 162.22
100 x N	0232 163.23
100 x O	0232 164.24
100 x P	0232 165.25
100 x Q	0232 166.26
100 x R	0232 167.27
100 x S	0232 168.00
100 x T	0232 169.01
100 x U	0232 170.06
100 x V	0232 171.23
100 x W	0232 172.24
100 x X	0232 173.25
100 x Y	0232 174.26
100 x Z	0232 175.27

RC610

100 x A	0233 150.03
100 x B	0233 151.20
100 x C	0233 152.21
100 x D	0233 153.22
100 x E	0233 154.23
100 x F	0233 155.24
100 x G	0233 156.25
100 x H	0233 157.26
100 x I	0233 158.07
100 x J	0233 159.00
100 x K	0233 160.05
100 x L	0233 161.22
100 x M	0233 162.23
100 x N	0233 163.24
100 x O	0233 164.25
100 x P	0233 165.26
100 x Q	0233 166.27
100 x R	0233 167.20
100 x S	0233 168.01
100 x T	0233 169.02
100 x U	0233 170.07
100 x V	0233 171.24
100 x W	0233 172.25
100 x X	0233 173.26
100 x Y	0233 174.27
100 x Z	0233 175.20

RC810

100 x A	0234 150.04
100 x B	0234 151.21
100 x C	0234 152.22
100 x D	0234 153.23
100 x E	0234 154.24
100 x F	0234 155.25
100 x G	0234 156.26
100 x H	0234 157.27
100 x I	0234 158.00
100 x J	0234 159.01
100 x K	0234 160.06
100 x L	0234 161.23
100 x M	0234 162.24
100 x N	0234 163.25
100 x O	0234 164.26
100 x P	0234 165.27
100 x Q	0234 166.20
100 x R	0234 167.21
100 x S	0234 168.02
100 x T	0234 169.03
100 x U	0234 170.00
100 x V	0234 171.25
100 x W	0234 172.26
100 x X	0234 173.27
100 x Y	0234 174.20
100 x Z	0234 175.21

RC Standard marker cards (cont.)

Horizontal marking of conventional symbols

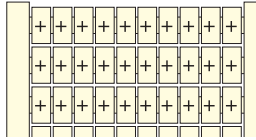
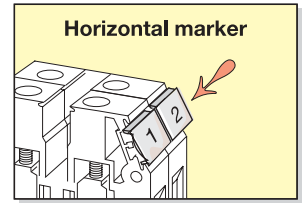

Horizontal marking
Repeated identical symbols

RC55	RC510	RC65	RC610	RC810
100 x + 0230 111.21	100 x + 0231 111.16	100 x + 0232 111.17	100 x + 0233 111.10	100 x + 0234 111.11
100 x - 0230 112.22	100 x - 0231 112.17	100 x - 0232 112.10	100 x - 0233 112.11	100 x - 0234 112.12
100 x ~ 0230 114.24	100 x ~ 0231 114.11	100 x ~ 0232 114.12	100 x ~ 0233 114.13	100 x ~ 0234 114.14
100 x = 0230 113.23	100 x = 0231 113.10	100 x = 0232 113.11	100 x = 0233 113.12	100 x = 0234 113.13
100 x ± 0230 115.25	100 x ± 0231 115.12	100 x ± 0232 115.13	100 x ± 0233 115.14	100 x ± 0234 115.15

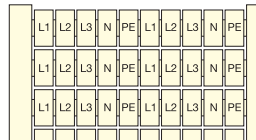

Horizontal marking
Conventional symbols

Markers	Marking method	Marker width mm	Marker height, L mm	Use with terminal block thickness
RC55	⑤ ⑩	5	5	5 mm
RC510	⑥ ⑩	5	10	5 mm
RC65	⑤ ⑪	6	5	6 mm
RC610	⑥ ⑪	6	10	6 mm
RC810	⑥ ⑰	8	10	8 mm and larger

RC55	RC510	RC65	RC610
20 x L1-L2-L3-N-PE 0230 131.25	20 x L1-L2-L3-N-PE 0231 131.12	20 x L1-L2-L3-N-PE 0232 131.13	20 x L1-L2-L3-N-PE 0233 131.14



Horizontal marking
Conventional symbols

RC55	RC510	RC65	RC610
100 x L1 0230 116.26	100 x L1 0231 116.13	100 x L1 0232 116.14	100 x L1 0233 116.15
100 x L2 0230 117.27	100 x L2 0231 117.14	100 x L2 0232 117.15	100 x L2 0233 117.16
100 x L3 0230 118.00	100 x L3 0231 118.25	100 x L3 0232 118.26	100 x L3 0233 118.27
100 x PE 0230 119.01	100 x PE 0231 119.26	100 x PE 0232 119.27	100 x PE 0233 119.20

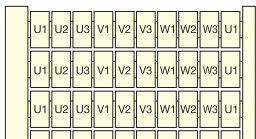

Horizontal marking
Conventional symbols

RC65	RC610
10 times U1-U2-U3-V1-V2-V3 W1-W2-W3 0232 132.14	10 times U1-U2-U3-V1-V2-V3 W1-W2-W3 0233 132.15

RC Standard marker cards (cont.)

Vertical marking of numbers

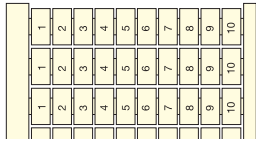

Vertical marking
Increasing order repeated 10 times

Markers	Marking method	Marker width mm	Marker height, L mm	Use with terminal block thickness
RC55	⑤ ⑩	5	5	5 mm
RC510	⑥ ⑩	5	10	5 mm
RC65	⑤ ⑪	6	5	6 mm
RC610	⑥ ⑪	6	10	6 mm
RC810	⑥ ⑰	8	10	8 mm and larger

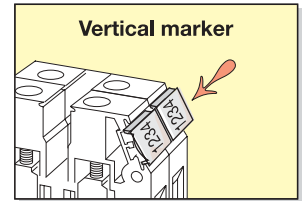

For horizontal markers, see page 1930.

RC55		RC510		RC65		RC610		RC810	
0 → 9	0230 040.11	0 → 9	0231 040.06	0 → 9	0232 040.07	0 → 9	0233 040.00	0 → 9	0234 040.01
1 → 10	0230 041.06	1 → 10	0231 041.23	1 → 10	0232 041.24	1 → 10	0233 041.25	1 → 10	0234 041.26
11 → 20	0230 042.07	11 → 20	0231 042.24	11 → 20	0232 042.25	11 → 20	0233 042.26	11 → 20	0234 042.27
21 → 30	0230 043.00	21 → 30	0231 043.25	21 → 30	0232 043.26	21 → 30	0233 043.27	21 → 30	0234 043.20
31 → 40	0230 044.01	31 → 40	0231 044.26	31 → 40	0232 044.27	31 → 40	0233 044.20	31 → 40	0234 044.21
41 → 50	0230 045.02	41 → 50	0231 045.27	41 → 50	0232 045.20	41 → 50	0233 045.21	41 → 50	0234 045.22
51 → 60	0230 046.03	51 → 60	0231 046.20	51 → 60	0232 046.21	51 → 60	0233 046.22	51 → 60	0234 046.23
61 → 70	0230 047.04	61 → 70	0231 047.21	61 → 70	0232 047.22	61 → 70	0233 047.23	61 → 70	0234 047.24
71 → 80	0230 048.15	71 → 80	0231 048.02	71 → 80	0232 048.03	71 → 80	0233 048.04	71 → 80	0234 048.05
81 → 90	0230 049.16	81 → 90	0231 049.03	81 → 90	0232 049.04	81 → 90	0233 049.05	81 → 90	0234 049.06
91 → 100	0230 050.13	91 → 100	0231 050.00	91 → 100	0232 050.01	91 → 100	0233 050.02	91 → 100	0234 050.03
101 → 110	0230 051.00	101 → 110	0231 051.25	101 → 110	0232 051.26	101 → 110	0233 051.27	101 → 110	0234 051.20
111 → 120	0230 052.01	111 → 120	0231 052.26	111 → 120	0232 052.27	111 → 120	0233 080.21	111 → 120	0234 052.21
121 → 130	0230 053.02	121 → 130	0231 053.27	121 → 130	0232 053.20	121 → 130	0233 081.16	121 → 130	0234 053.22
131 → 140	0230 054.03	131 → 140	0231 054.20	131 → 140	0232 054.21	131 → 140	0233 082.17	131 → 140	0234 054.23
141 → 150	0230 055.04	141 → 150	0231 055.21	141 → 150	0232 055.22	141 → 150	0233 083.10	141 → 150	0234 055.24
151 → 160	0230 056.05	151 → 160	0231 056.22	151 → 160	0232 056.23	151 → 160	0233 084.11	151 → 160	0234 056.25
161 → 170	0230 057.06	161 → 170	0231 057.23	161 → 170	0232 057.24	161 → 170	0233 085.12	161 → 170	0234 057.26
171 → 180	0230 058.17	171 → 180	0231 058.04	171 → 180	0232 058.05	171 → 180	0233 086.13	171 → 180	0234 058.07
181 → 190	0230 059.10	181 → 190	0231 059.05	181 → 190	0232 059.06	181 → 190	0233 087.14	181 → 190	0234 059.00
191 → 200	0230 072.05	191 → 200	0231 072.22	191 → 200	0232 072.23	191 → 200	0233 088.25	191 → 200	0234 072.25
201 → ...	0230 073.06*	201 → ...	0231 073.23*	201 → ...	0232 073.24*	201 → ...	0233 071.23*	201 → ...	0234 073.26*
... → 999		... → 999		... → 999		... → 999		... → 999	

* Part numbers identical for each group of numbers : on request (indicate marking). Ex. : 0230 073.06 : 301 to 310.

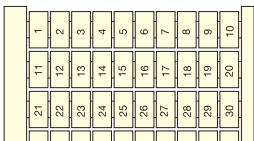

Vertical marking
Increasing marker



RC55		RC510		RC65		RC610		RC810	
1 → 100	0230 060.15	1 → 100	0231 060.02	1 → 100	0232 060.03	1 → 100	0233 060.04	1 → 100	0234 060.05
101 → 200	0230 061.02	101 → 200	0231 061.27	101 → 200	0232 061.20	101 → 200	0233 061.21	101 → 200	0234 061.22
201 → 300	0230 062.03	201 → 300	0231 062.20	201 → 300	0232 062.21	201 → 300	0233 062.22	201 → 300	0234 062.23
301 → 400	0230 063.04	301 → 400	0231 063.21	301 → 400	0232 063.22	301 → 400	0233 063.23	301 → 400	0234 063.24
401 → 500	0230 064.05	401 → 500	0231 064.22	401 → 500	0232 064.23	401 → 500	0233 064.24	401 → 500	0234 064.25
501 → 600	0230 065.06	501 → 600	0231 065.23	501 → 600	0232 065.24	501 → 600	0233 065.25	501 → 600	0234 065.26
601 → 700	0230 066.07	601 → 700	0231 066.24	601 → 700	0232 066.25	601 → 700	0233 066.26	601 → 700	0234 066.27
701 → 800	0230 067.00	701 → 800	0231 067.25	701 → 800	0232 067.26	701 → 800	0233 067.27	701 → 800	0234 067.20
801 → 900	0230 068.11	801 → 900	0231 068.06	801 → 900	0232 068.07	801 → 900	0233 068.00	801 → 900	0234 068.01
901 → 1000	0230 069.12	901 → 1000	0231 069.07	901 → 1000	0232 069.00	901 → 1000	0233 069.01	901 → 1000	0234 069.02
1001 → ...	0230 070.17*	1001 → ...	0231 070.04*	1001 → ...	0232 070.05*	1001 → ...	0233 070.06*	1001 → ...	0234 070.07*

* Part numbers identical for each group of numbers : on request (indicate marking). Ex. : 0230 070.17 : 1001 to 1100.

RC Standard marker cards (cont.)

Vertical marking of numbers (cont.)

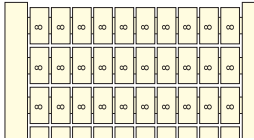

Vertical marking
Repeated identical numbers

Markers	Marking method	Marker width mm	Marker height, L mm	Use with terminal block thickness
RC55	⑤ ⑩	5	5	5 mm
RC510	⑥ ⑩	5	10	5 mm
RC65	⑤ ⑪	6	5	6 mm
RC610	⑥ ⑪	6	10	6 mm
RC810	⑥ ⑰	8	10	8 mm and larger

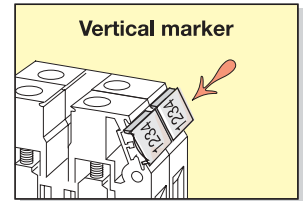

RC65

100 x 0	0232 240.14
100 x 1	0232 241.01
100 x 2	0232 242.02
100 x 3	0232 243.03
100 x 4	0232 244.04
100 x 5	0232 245.05
100 x 6 or 9	0232 246.06
100 x 7	0232 247.07
100 x 8	0232 248.10
100 x 10	0232 250.16
100 x 11	0232 251.03
100 x 12	0232 252.04
100 x 13	0232 253.05
100 x 14	0232 254.06
100 x 15	0232 255.07
100 x 16	0232 256.00
100 x 17	0232 257.01
100 x 18	0232 258.12
100 x 19	0232 259.13
100 x 20	0232 260.10
100 x ..	0232 261.05*
999	

RC610

100 x 0	0233 240.15
100 x 1	0233 241.02
100 x 2	0233 242.03
100 x 3	0233 243.04
100 x 4	0233 244.05
100 x 5	0233 245.06
100 x 6 or 9	0233 246.07
100 x 7	0233 247.00
100 x 8	0233 248.11
100 x 10	0233 250.17
100 x 11	0233 251.04
100 x 12	0233 252.05
100 x 13	0233 253.06
100 x 14	0233 254.07
100 x 15	0233 255.00
100 x 16	0233 256.01
100 x 17	0233 257.02
100 x 18	0233 258.13
100 x 19	0233 259.14
100 x 20	0233 260.11
100 x ..	0233 261.06*
999	



Vertical marking
Alternate even/odd numbered for 2 deck block **M 4/6.D**

RC610

1	→	20	0233 143.20
21	→	40	0233 144.21
41	→	60	0233 145.22
61	→	80	0233 146.23
81	→	100	0233 147.24

* Part numbers identical for each group of numbers : on request (indicate marking). Ex. : 0232 261.05 : 100 x 25.

Vertical marking of symbols

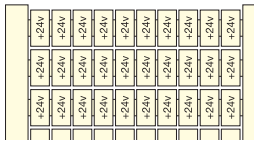

Vertical marking
Repeated identical symbols

RC610

100 x +24V	0233 124.15
100 x +48V	0233 125.16